

16830



Call Us First!
DO NOT RETURN TO STORE.

For immediate help with assembly or product information

call our toll free number:

1-800-844-9273

or email:

customerservice@yardline.net

Our staff is ready to provide assistance

April through October M-F 8:00 AM to 6:00 PM EST

Saturday 8:30 AM to 4:30 PM EST

November through March M - F 8:00 AM to 5:00 PM EST

(This page intentionally left blank.)



A Backyard Products Company

ASSEMBLY MANUAL

16830

09/25/2018

ABERDEEN 12' x 8' Wide Gable (365,8 x 243,8 cm)

KEEP THIS MANUAL FOR FUTURE REFERENCE

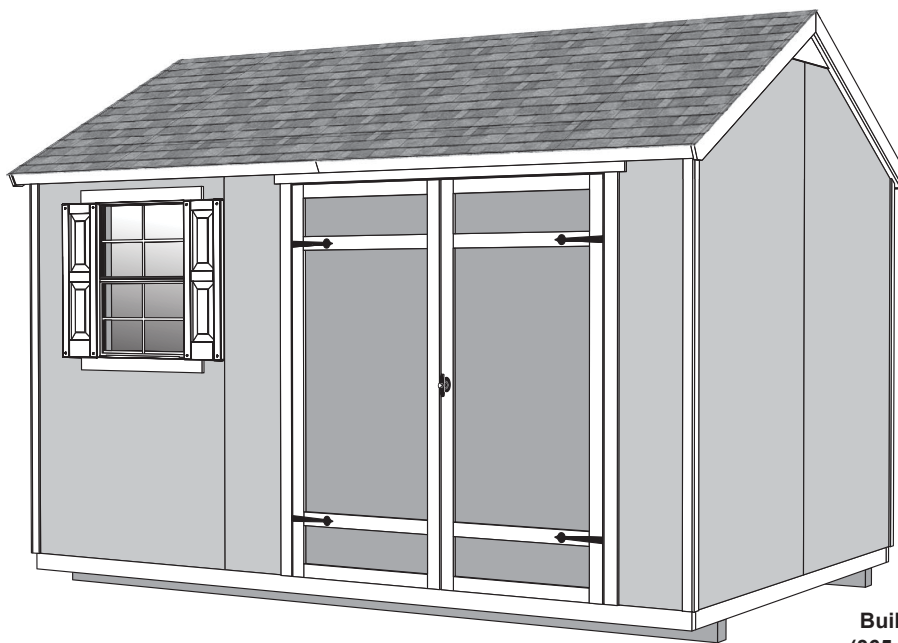

Building 12' x 8'
(365,8 x 243,8 cm)

⚠ **IMPORTANT!** ⚠

READ INSTRUCTIONS THOROUGHLY PRIOR TO BEGINNING ASSEMBLY.

BEFORE YOU BEGIN

- **BUILDING RESTRICTIONS AND APPROVALS**

Be sure to check local building department and homeowners association for specific restrictions and/ or requirements before building.

- **ENGINEERED DRAWINGS**

Contact our Customer Service Team if engineered drawings are needed to pull local permits.

- **SURFACE PREPARATION**

To ensure proper assembly you must build your shed on a level surface. Recommended methods and materials to level your shed are listed on page 7.

- **CHECK ALL PARTS**

Inventory all parts listed on pages 4-6. Contact our Customer Service Team if any parts are missing or damaged.

- **ADDITIONAL MATERIALS**

You will need additional materials to complete your shed. See page 3 for required and optional materials and quantities.



- **CUSTOMER SERVICE** -

Call: 1-800-844-9273 email: customerservice@yardline.net





TOOLS

Required

Phillips Screwdriver 

Drill / Driver
 3/8" Drill Bit
 #2 Phillips Drive Bit

Hammer 

Pencil 

Tape Measure 

Square 

Level 

Chalk Line 

Utility Knife
 Shingle Blades 

Caulk Gun 

Exterior rated Wood Glue 

Ladder 

Paint Tools 

Optional

Tool Belt/ Nail Pouch 

Safety Glasses 

Nail Gun
 • Gun Nails 

Gloves 

Clamps 

Safety! Always use approved safety glasses during assembly.

HELPFUL REMINDER SYMBOLS

Look for these symbols for helpful reminders throughout this manual.

 = Assistance Required; two or more people.

 = Mark part with pencil.

 = Ensure squareness.

 **BEGIN** = Beginning of steps for assembly or installation.

 = Important required step or operation.

 **FINISH** = You have finished the assembly or installation.

 = Helpful assembly hint.

 = Level

ORIENT LUMBER AND TRIM FOR BEST APPEARANCE

Framing lumber is graded for structural strength and not appearance. Exterior trim is graded for one good side.

Always install the material leaving the best edge and best surface visible. Please remember that these blemishes in no way negatively affect the strength or integrity of our product. (See Fig. A, B, C.)

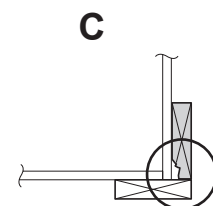
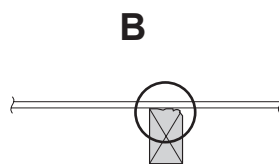
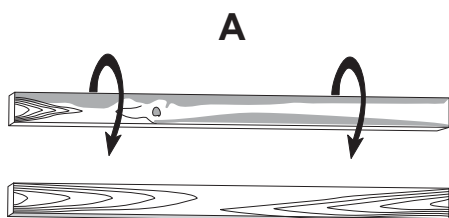

ADDITIONAL MATERIALS

FOUNDATION OR FLOOR MATERIALS

- See the FLOOR LEVELING section on page 7 for recommended methods and suggested materials to properly level your floor, as this will vary depending on your specific site.

REINFORCED WOOD FLOOR FRAME (OPTIONAL)

IMPORTANT! Depending on your specific use, you may want to construct a heavy duty floor frame by adding additional floor joists (shown below as shaded). Below is a list of additional materials (not included).

- x3** 2 x 4 x 8' (5,1 x 10,2 x 243,8 cm) Treated Lumber
Cut lumber to 2 x 4 x 93" (5,1 x 10,2 x 236,2 cm)
Treated Lumber
- x12** ea. 3" (7,6 cm) hot-dipped galvanized nails

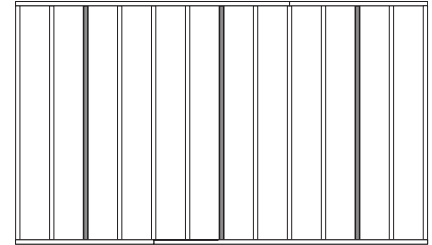

Optional 12" (30,5 cm) spacing

COMPLETING YOUR SHED

You will need these additional materials:

- 3-TAB SHINGLES**.....6 Bundles
- 1" GALVANIZED ROOFING NAILS**.... 3 Lbs
For shingles.
- PAINT FOR SIDING**2 Gallons
Use 100% acrylic latex exterior paint. (2) coats recommended.
- PAINT FOR TRIM** 1 Quart
Use 100% acrylic latex exterior paint.
- CAULK**.....3 Tubes
Use acrylic latex exterior caulk that is paintable. 
- WOOD GLUE** Exterior Rated

OPTIONAL MATERIALS

- DRIP EDGE** 50 Feet
- #15 ROOFING FELT**
To cover 148 Sq. Ft. of roof area.
- 1" GALVANIZED ROOFING NAILS**.....1/4 Lb
For roofing felt.

REFER TO THE BACK OF THIS MANUAL AND THE MANUFACTURER'S INSTRUCTIONS FOR INSTALLATION OF SHINGLES, DRIP EDGE AND FELT.

PARTS IDENTIFICATION AND SIZES

Part identification is stamped on some parts.

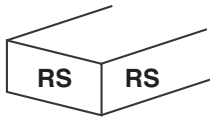

• Check these locations for Part stamps

WOOD SIZE CONVERSION CHART

Nominal Board Size	Actual Size
2" x 4"	1-1/2" x 3-1/2" (3,8 x 8,9 cm)
1" x 4"	3/4" x 3-1/2" (1,9 x 8,9 cm)
2" x 3"	1-1/2" x 2-1/2" (3,8 x 6,3 cm)
1" x 3"	3/4" x 2-1/2" (1,9 x 6,3 cm)

PARTS LIST



INVENTORY YOUR PARTS before you begin.

We suggest sorting parts by the category they are listed in.

WALLS

- x1 **PU** 2 x 4 x 3-1/2" (5,1 x 10,2 x 8,9 cm)
- x1 **RB** 2 x 4 x 16" (5,1 x 10,2 x 40,6 cm)
- x2 **AO** 2 x 4 x 22-1/2" (5,1 x 10,2 x 57,2 cm)
- x2 **ED** 2 x 3 x 26" (5,1 x 7,6 x 66 cm)
- x3 **SP** 2 x 4 x 48" (5,1 x 10,2 x 121,9 cm)
- x1 **UX** 2 x 4 x 64" (5,1 x 10,2 x 162,6 cm)
- x1 7/16 x 3-1/4 x 67" (1,1 x 8,3 x 170,2 cm) OSB
- x2 **AM** 2 x 4 x 67" (5,1 x 10,2 x 170,2 cm)
- x2 **YFA** 2 x 4 x 68-1/2" (5,1 x 10,2 x 174 cm)
- x24 **TM** 2 x 4 x 72" (5,1 x 10,2 x 182,9 cm)
- x4 **SZ** 2 x 4 x 89" (5,1 x 10,2 x 226,1 cm)
- x3 **TP** 2 x 4 x 96" (5,1 x 10,2 x 243,8 cm)

x1 **GAA** 1 x 3 x 5" (2,5 x 7,6 x 12,7 cm)
Gauge Block for 3/4" (1,9 cm) measurement

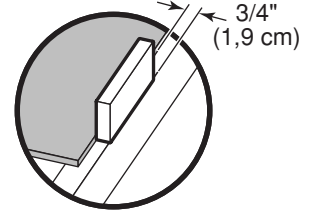

ROOF

- x10 **GUSSET**
- x10 **AA** 2 x 4 x 55-3/16" (5,1 x 10,2 x 140,2 cm)
- x2 **GUA** 1 x 3 x 60" (2,5 x 7,6 x 152,4 cm)

TRIM

- x2 **AZ** 19/32 x 3 x 30-1/8" (1,5 x 7,6 x 76,5 cm)
- x2 **AN** 2 x 4 x 48-3/4" (5,1 x 10,2 x 123,8 cm)
- x4 **ETA** 2 x 3 x 59" (5,1 x 7,6 x 149,9 cm)
- x2 **GFL** 19/32 x 3-1/2 x 60" (1,5 x 8,9 x 152,4 cm)
- x2 **GFR** 19/32 x 3-1/2 x 60" (1,5 x 8,9 x 152,4 cm)
- x1 **ZO** 19/32 x 4 x 72" (1,5 x 10,2 x 182,9 cm)
- x4 3/8 x 2-1/2 x 73-7/8" (1,0 x 6,3 x 187,6 cm)
- x4 3/8 x 1-3/4 x 75-3/4" (1 x 4,4 x 192,4 cm)
- x2 3/8 x 1-3/4 x 75-7/16" (1 x 4,4 x 191,6 cm)
- x2 3/8 x 1-3/4 x 75-7/16" (1 x 4,4 x 191,6 cm)
- x2 **TP** 2 x 4 x 96" (5,1 x 10,2 x 243,8 cm)

DOOR

- x4 **AH** 19/32 x 2-1/2 x 26-5/8" (1,5 x 6,3 x 67,6 cm)
- x2 **OO** 1-1/4 x 2-1/2 x 69" (3,2 x 6,3 x 175,3 cm)

WALL PANEL & DOOR PARTS LIST

NOTE: Panel parts are not stamped with part identification.

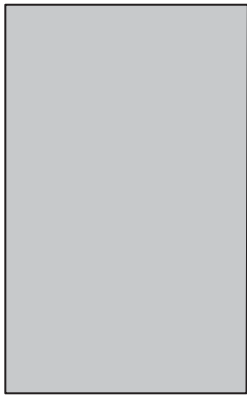

x3
3/8 x 48 x 76"
(1 x 121,9 x 193 cm)

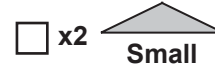

x2

Small



x2

Large

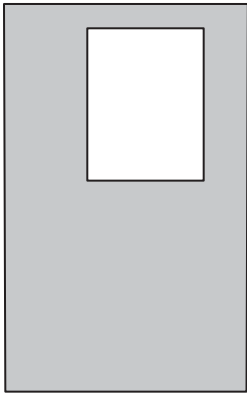

x1
3/8 x 48 x 76"
(1 x 121,9 x 193 cm)

x1
3/8 x 48 x 76"
(1 x 121,9 x 193 cm)

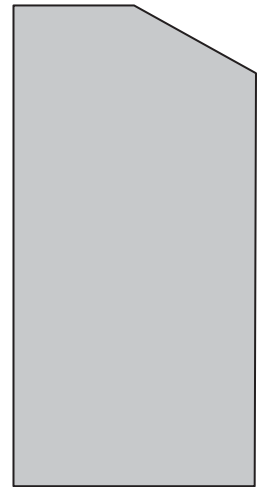
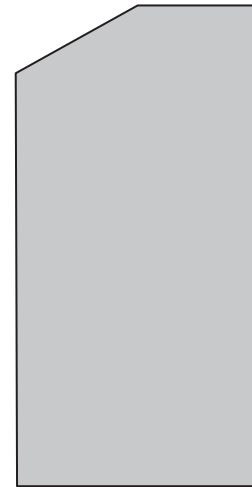
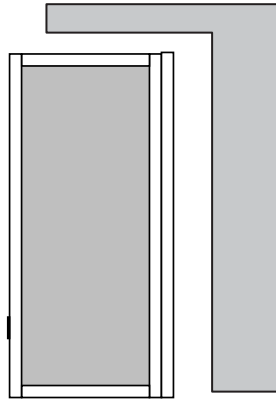
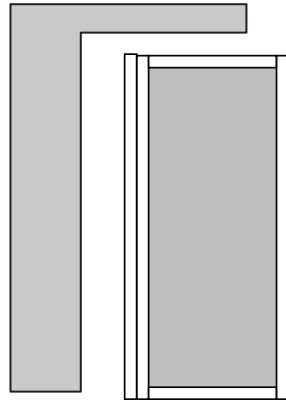

x1
3/8 x 48 x 76"
(1 x 121,9 x 193 cm)

x1
LEFT DOOR

x1
RIGHT DOOR

x2
3/8 x 48 x 96"
(1 x 121,9 x 243,8 cm)

x2
3/8 x 48 x 96"
(1 x 121,9 x 243,8 cm)

ROOF PANELS

x2  7/16 x 11 x 96"
(1,1 x 27,9 x 243,8 cm)

x4  7/16 x 11 x 25-5/8"
(1,1 x 27,9 x 65,1 cm)

x2  7/16 x 48 x 96"
(1,1 x 121,9 x 243,8 cm)

x4  7/16 x 25-5/8 x 48"
(1,1 x 65,1 x 121,9 cm)

**Roof panels are
7/16" (1,1 cm) thick.**

SHELF AND LOFT



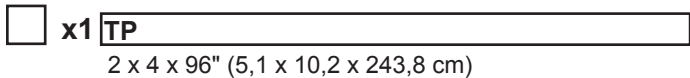
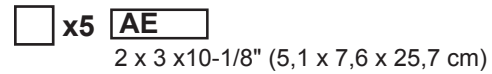
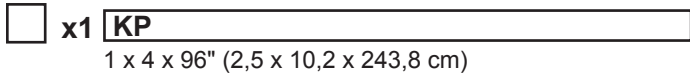
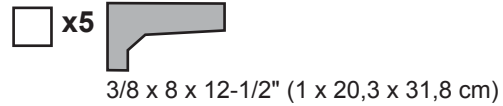
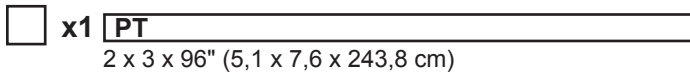
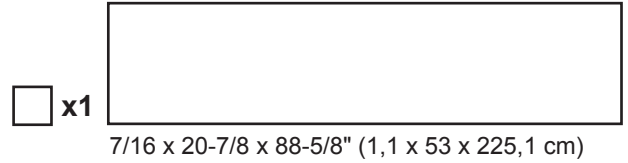
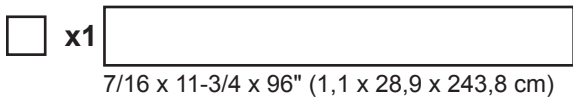

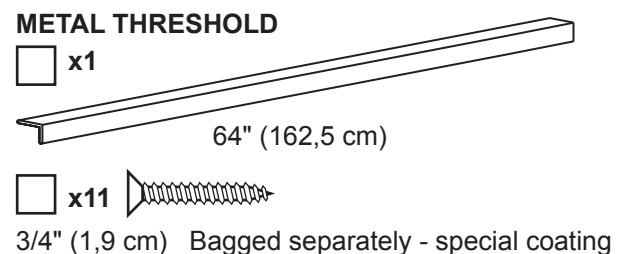
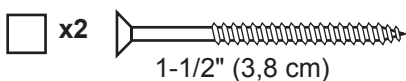
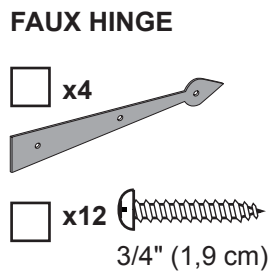
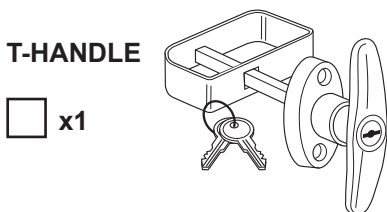
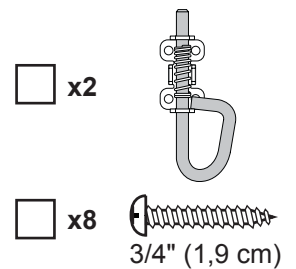
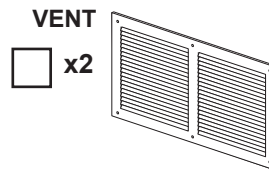
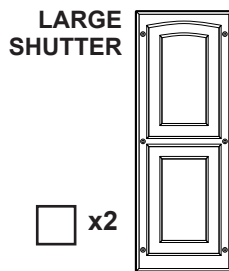
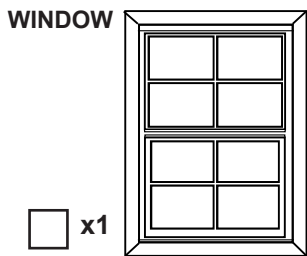

Loft and shelf panels are 7/16" (1,1 cm) thick.

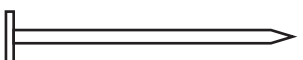
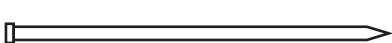

ACCESSORIES & DOOR HARDWARE



FASTENER/HARDWARE BAG

- x 72  1-1/2" (3,8 cm)
- x 153  2" (5,0 cm)
- x 51  3" (7,6 cm)
- x 22  2" (5,0 cm)
- x 78  1-1/4" (3,2)
- x 12  1/2" (1,3 cm)
- x 60  3/4" (1,9 cm)

There are multiple ways to level your floor frame. Our recommended leveling method is shown below. Leveling materials are not included in this kit.

PREFERRED METHOD - 4x4 TREATED RUNNERS

- 3" (7,6 cm) Screws angled into 4x4.
- (2) at each point frame and 4x4 touch.

Measurements to centers of 4x4's.
12"
(30,5 cm)

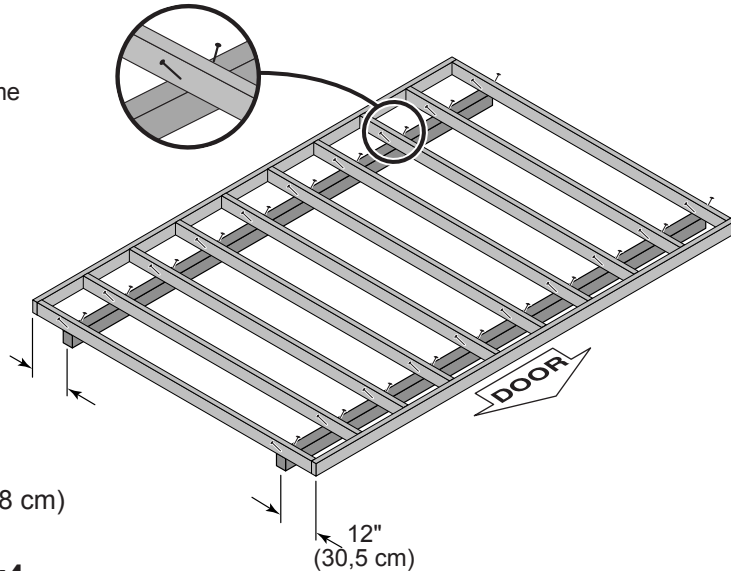

MATERIAL REQUIRED

x2 4x4 x 12' (10,2 x 10,2 x 365,8 cm) Treated Lumber

Fasteners for Frame to 4x4. (3" (7,6 cm) Screws shown as one option.) Minimum (40) 3" (7,6 cm) screws / exterior grade.

! Use only wood treated for ground contact and fasteners approved for use with treated wood.

! Always support frame seams.

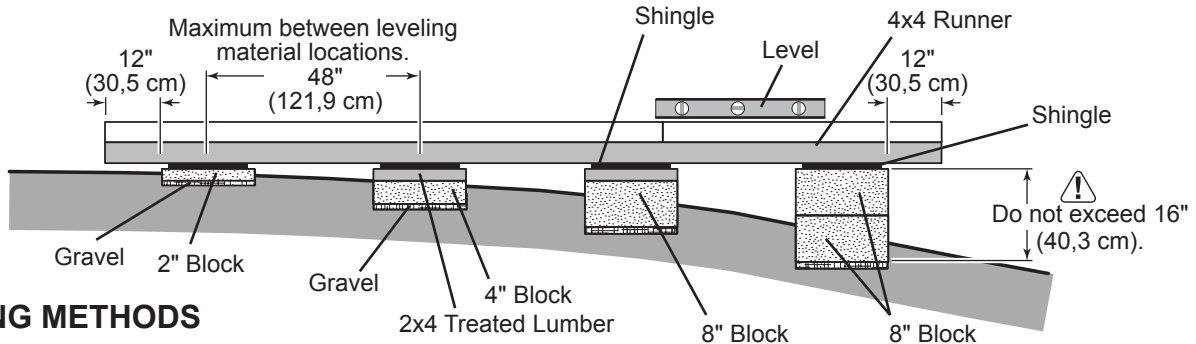

LEVELING METHODS

- Level under 4x4 runners only.
- Locate leveling material 12" (30,5 cm) from ends of runners and no more than 48" (121,9 cm) apart.
- Asphalt shingles should be used between 4x4 runners and blocks or treated lumber. Never use shingles in direct contact with ground.
- For best results and aiding in water drainage use gravel under each concrete block.

LEVELING MATERIALS

- Gravel
- Solid Masonry Blocks in 1", 2", 4" or 8" thickness
- 2x4 Treated Lumber
- Asphalt Shingles

! Leveling higher than 16" (40,3 cm) not recommended.

CONCRETE

- If you are building your shed on a concrete foundation see the following page.

CONCRETE FOUNDATION

Your kit contains all materials to construct a wooden floor.
If you choose to install your kit on a concrete slab refer to the diagram below.

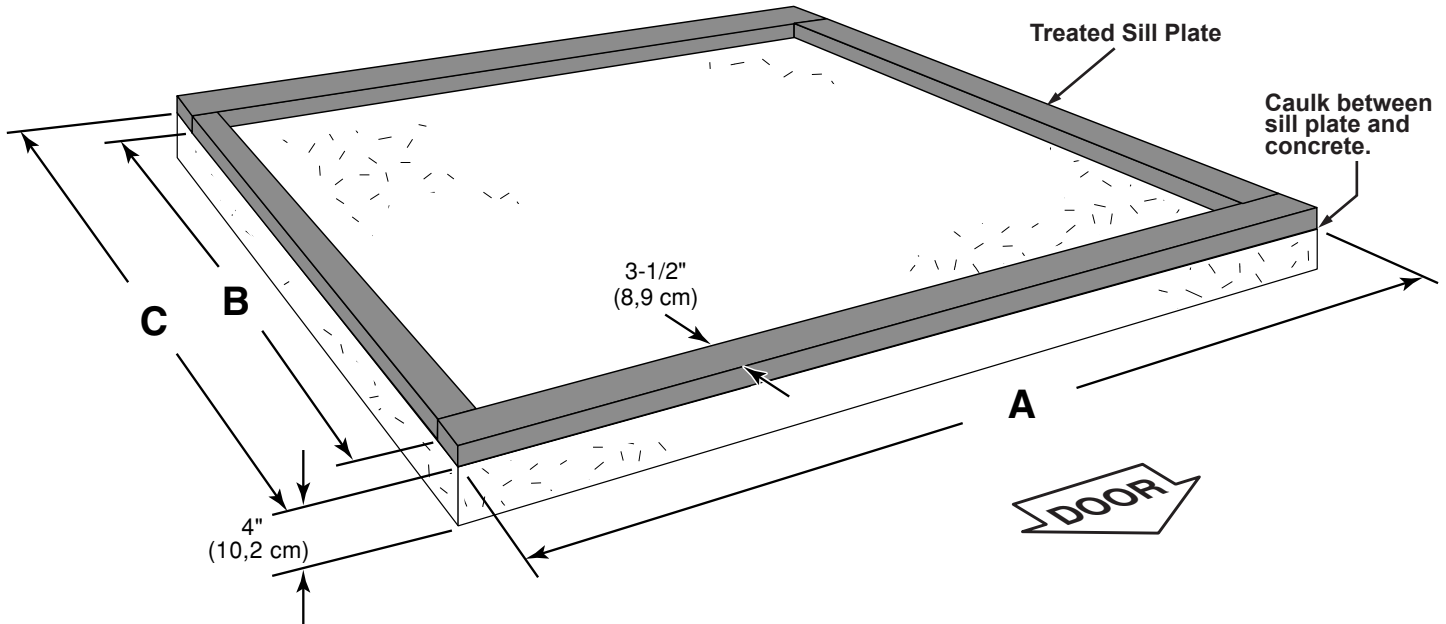

Building Size	Actual Size	A	B	C
12' x 8' (365,8 x 243,8 cm)	144" x 96" (365,8 x 243,8 cm)	144 " (365,8 cm)	89" (226,1 cm)	96" (243,8 cm)

Requires:

- x2 2 x 4 x 12' (5,1 x 10,2 x 365,8 cm) **MUST be treated lumber.**
- x2 2 x 4 x 8' (5,1 x 10,2 x 243,8 cm) **MUST be treated lumber.**
- x1 Caulk

Allow new concrete slabs to cure for at least seven (7) days.

• A treated 2 x 4 (5,1 x 10,2 cm) sill plate is required when installing your shed on concrete.
Hint: Purchase full length treated lumber.

- Use a high quality exterior grade caulk beneath all sill plates.
- Fasten 2 x 4 (5,1 x 10,2 cm) sill plates to slab using approved concrete anchors (**fasteners not included**).
- Check local code for concrete foundation requirements.

NOTES

FLOOR FRAME

PARTS REQUIRED:

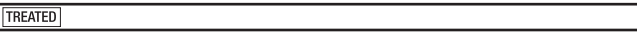
x10  **TREATED**
2 x 4 x 93" (5,1 x 10,2 x 236,2 cm)

x2  **TREATED**
2 x 4 x 144" (5,1 x 10,2 x 265,8 cm)

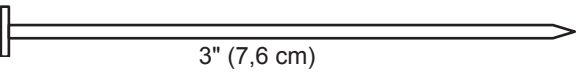
x40  3" (7,6 cm)

Look for
TREATED
Stamp

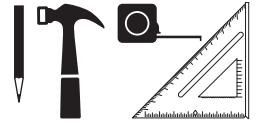

✓ BEGIN

- 1 Orient parts as shown on flat surface. Measure and mark.
Use (2) 3" nails at each mark.



HINT:
For easier nailing
stand on frame.

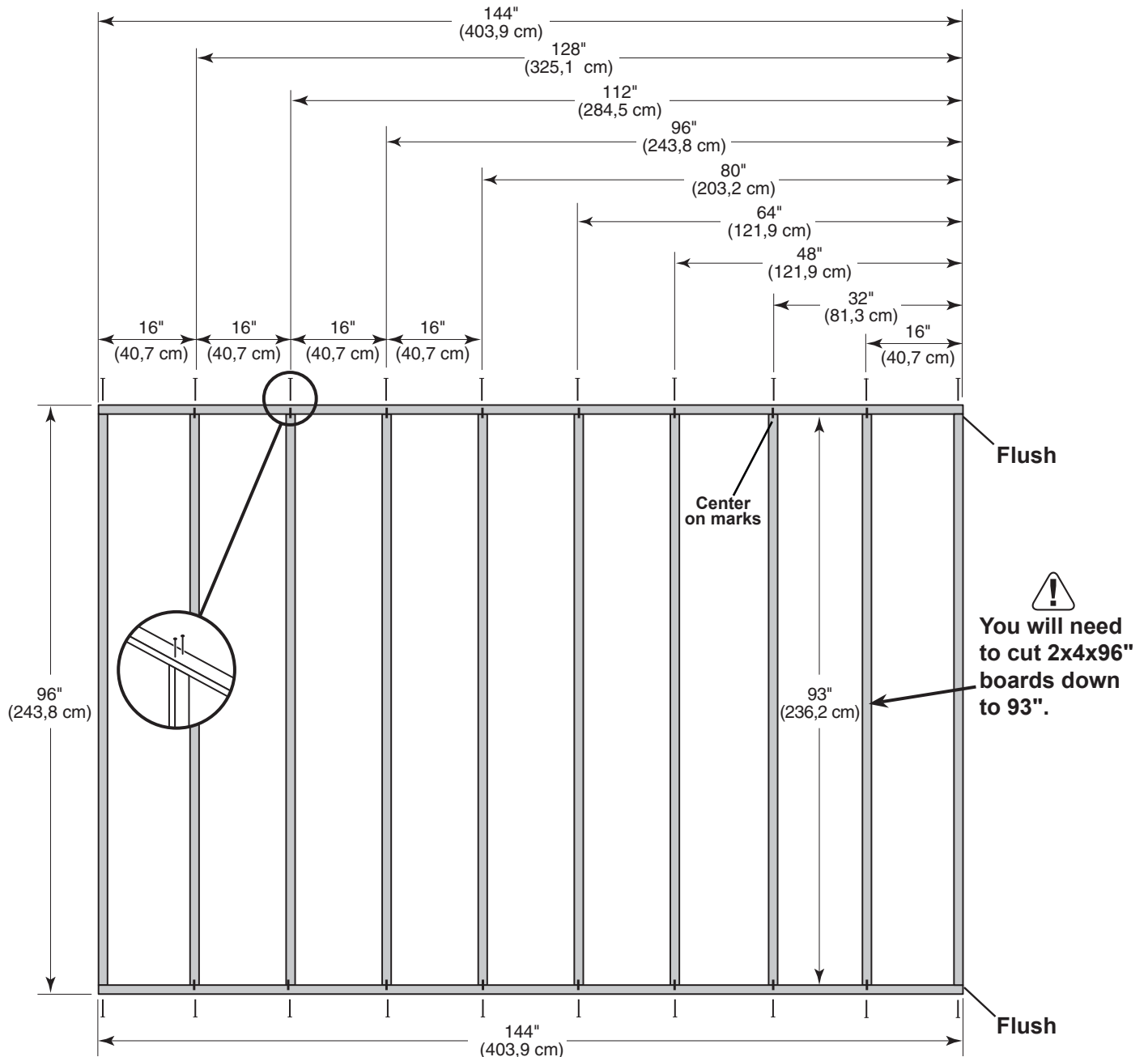
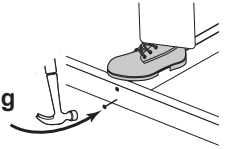

You have finished your floor frame. Proceed to level and square frame.

FLOOR FRAME

STOP!



LEVEL AND SQUARE FLOOR FRAME



Before attaching floor decking, it is important to level and square the floor frame. A level and square floor frame is required to correctly construct your shed.

STOP!



✓ **BEGIN**

1 ⚠ See page 7 for the preferred floor leveling method.

2 Use level and check the frame is level before applying floor panels.

3 Check for frame squareness by measuring diagonally across corners. If the measurements are the same, the frame is square. The diagonal measurement will be approximately 173-1/16" (439,6 cm).

4 When the frame is level and square secure one side of frame to the 4x4 runners using one fastener at ends of each runner. Move to the opposite end of the frame. Secure the frame to 4x4 runners with one fastener at ends of each runner making sure the frame remains square (**Fig. A**).



FINISH

Once the floor frame is level and square fasten the frame to at each point the frame contacts the 4x4 runners .

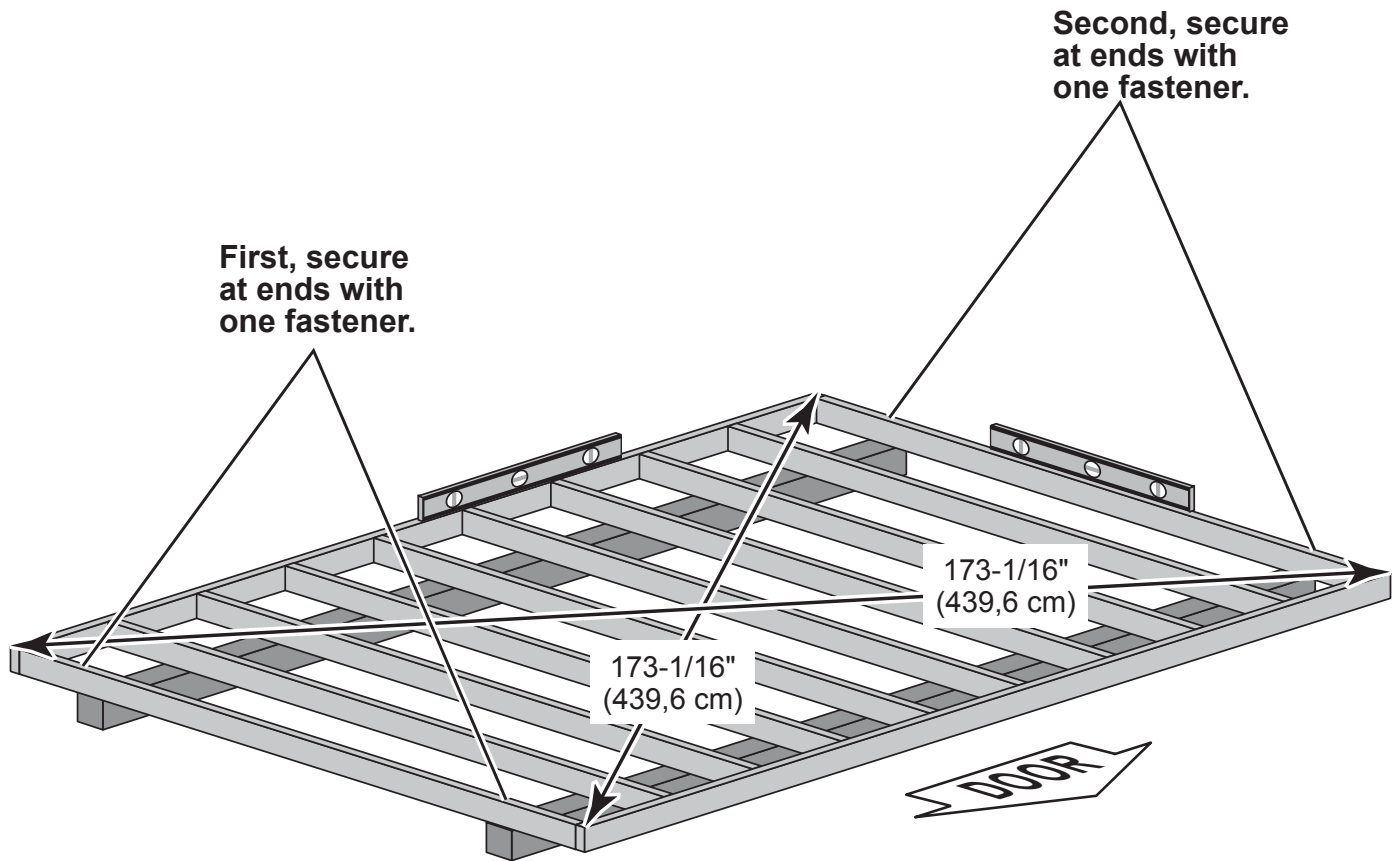
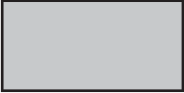

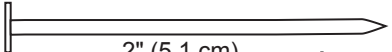

Fig. A

FLOOR PANELS

PARTS REQUIRED:

x3  5/8 x 48 x 96"
(1,6 x 121,9 x 243,8 cm)

 **GAA**
**3/4" GAUGE
BLOCK**

x186  2" (5,1 cm)

✓ **BEGIN**

- 1 Place right 48"x 96" panel on frame with rough side up (painted grid lines), flush at edges. Use **GAA** as a gauge block to maintain the 3/4" measurement on the floor joist. Secure the panel using 2" nails 6" apart on edges and 12" apart inside panel.

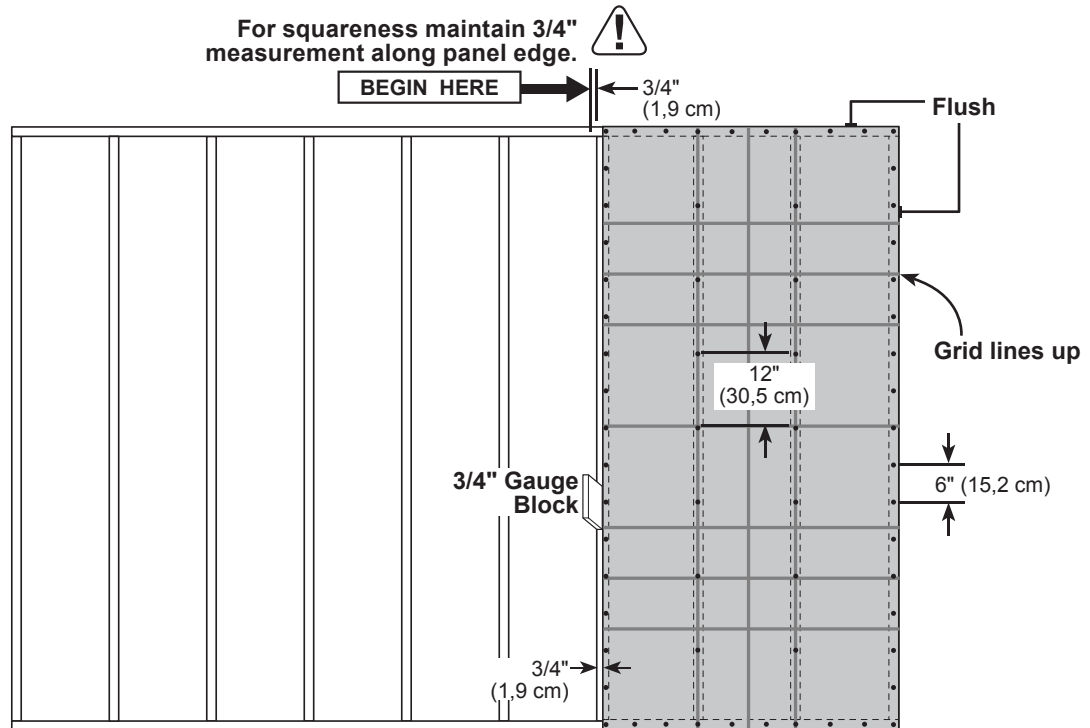

- 2 Continue installing 2 more 48"x 96" panels as in STEP - 1. Install middle panel first. Secure panels using 2" nails 6" apart on edges and 12" apart inside panels.

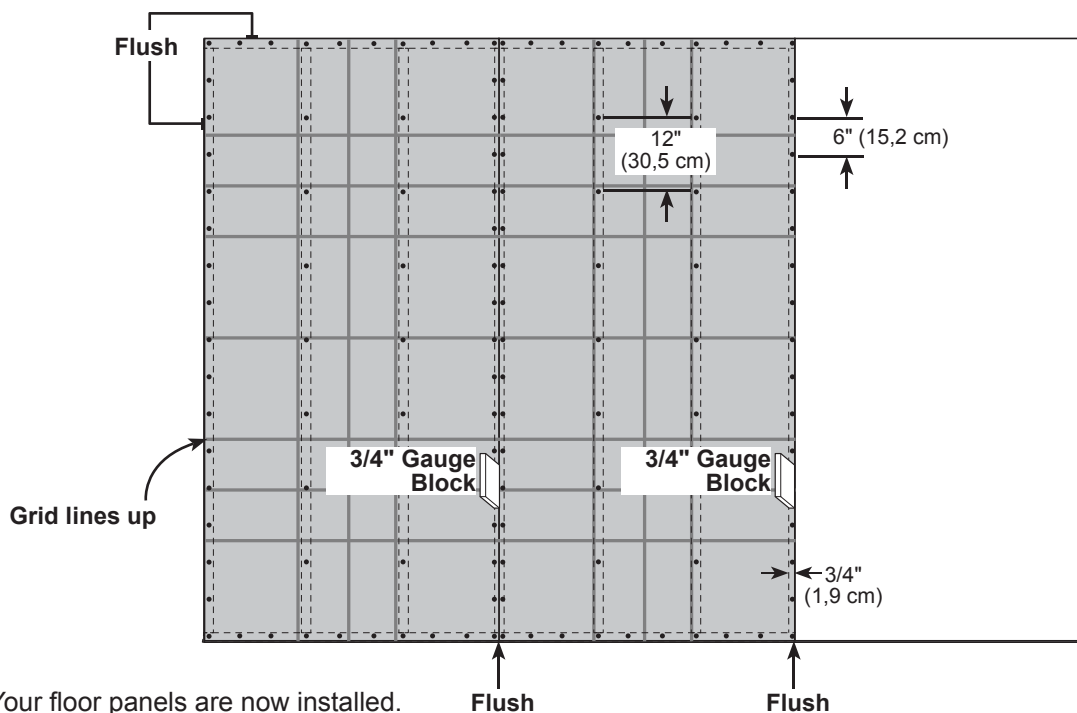

FINISH

Your floor panels are now installed.

IMPORTANT!

STOP!

Check that the floor frame is level after installing floor panels.
Re-level if needed.

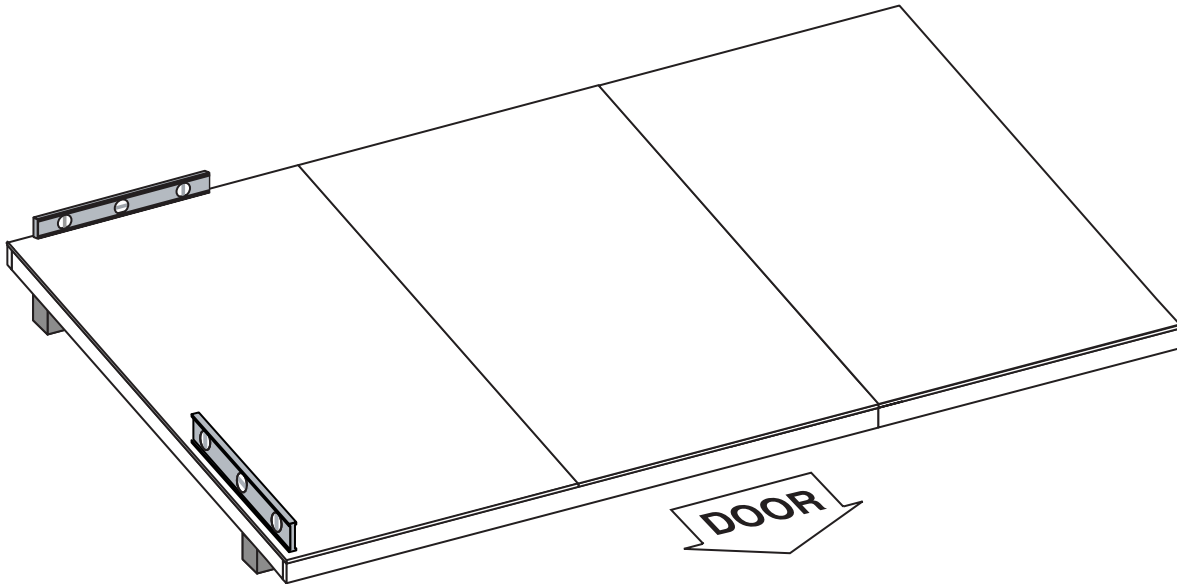

HINT:

- The floor should be used as a level work surface for wall construction.
- Organize your wall sections during sub-assembly to avoid over-handling of the walls.

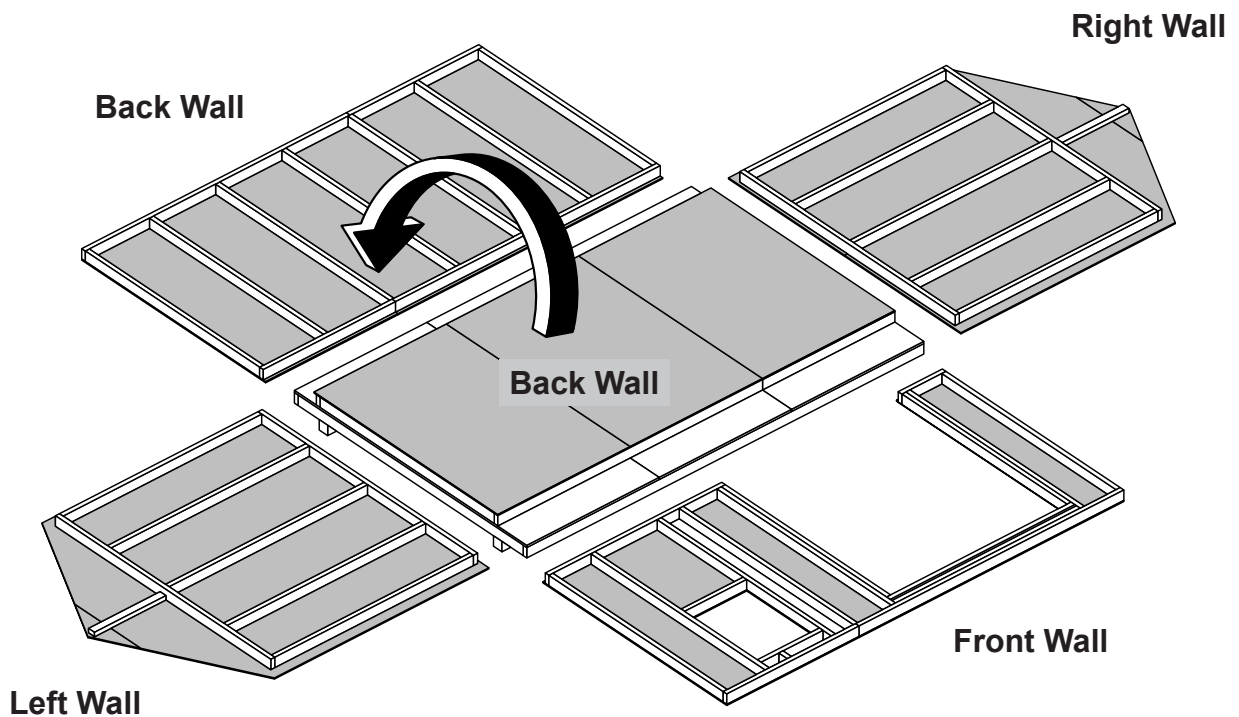

BACK WALL FRAME

PARTS REQUIRED:

x2 **SP**
2 x 4 x 48" (5,1 x 10,2 x 121,9 cm)

x7 **TM**
2 x 4 x 72" (5,1 x 10,2 x 182,9 cm)

x2 **TP**
2 x 4 x 96" (5,1 x 10,2 x 243,8 cm)

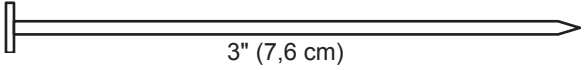
x32  3" (7,6 cm)

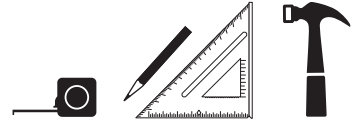

NOTE: Dimensions are to center of studs.

✓ **BEGIN**

- 1 Orient parts on edge on floor as shown. Measure and mark.
Use (2) 3" nails at each mark and (4) 3" nails at seams.



HINT:
For easier nailing
stand on frame.

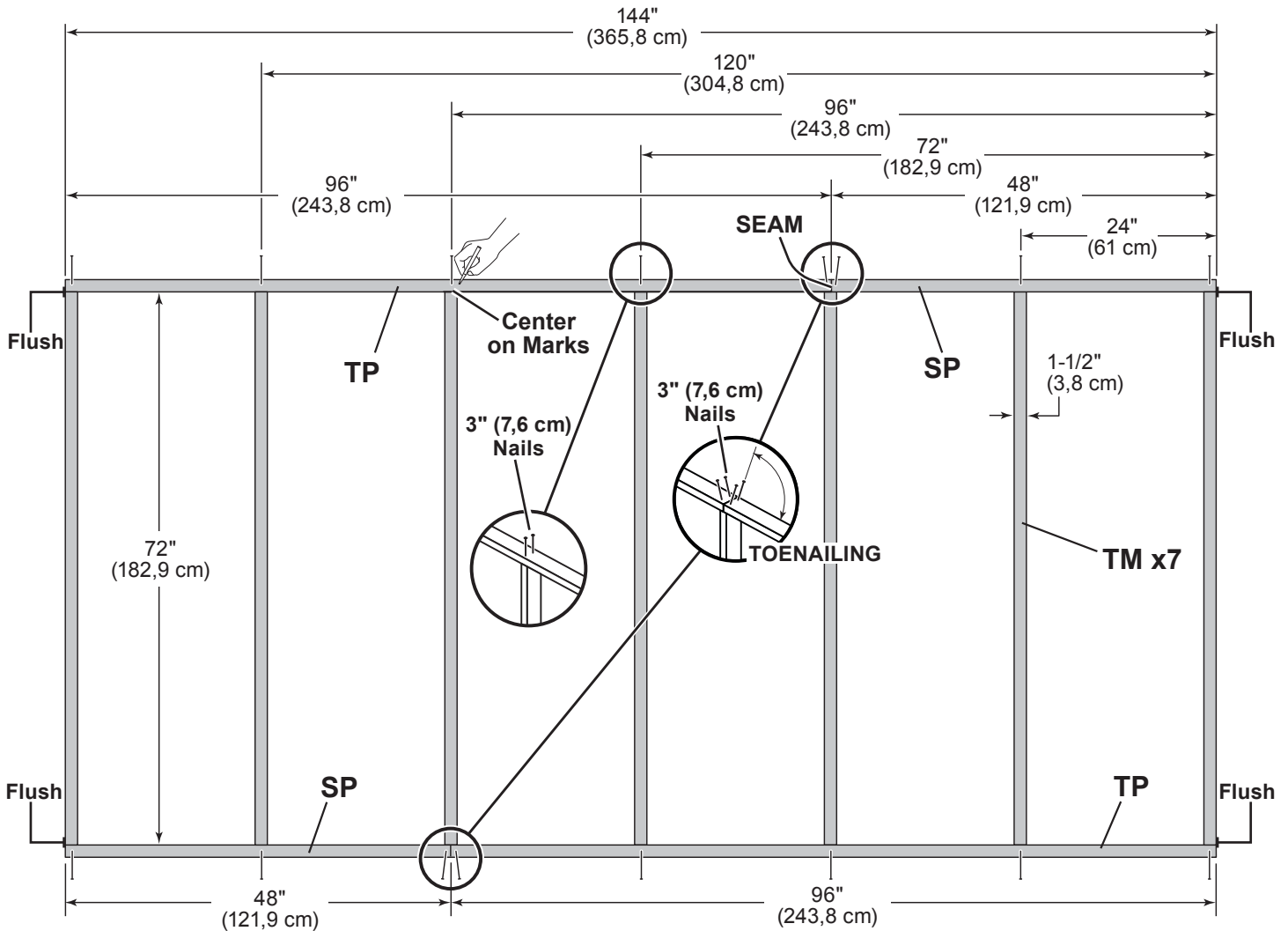
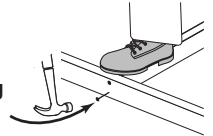

BACK WALL

PARTS REQUIRED:

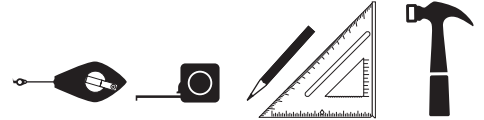
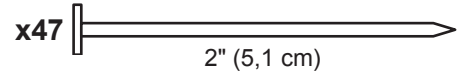
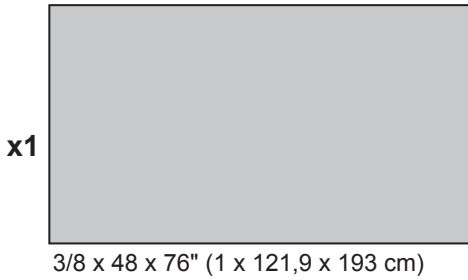

Ensure your wall frame is square by installing one panel and squaring frame.

2

Place first 48 x 76" panel onto wall frame as shown. Use the **GAA** gauge block to mark the 3/4" measurement on the wall stud. Secure panel with two 2" nails in the corners (**Fig. A**).

3

Move to the opposite end. Using the long edge of the panel as a lever move the panel side-to-side until you have a 3/4" measurement on the wall stud. Secure corner with two 2" nails (**Fig. B**).

Nail the panel using 2" nails 6" apart on edges and 12" apart inside panel.

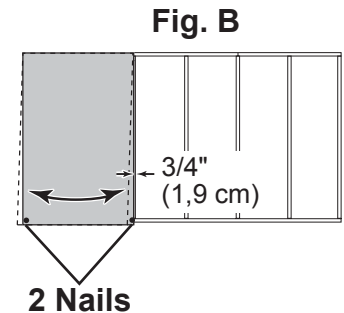
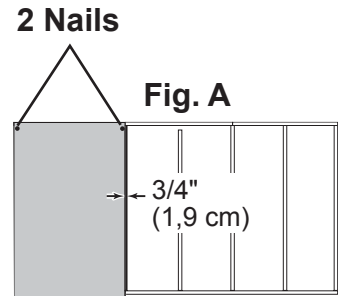
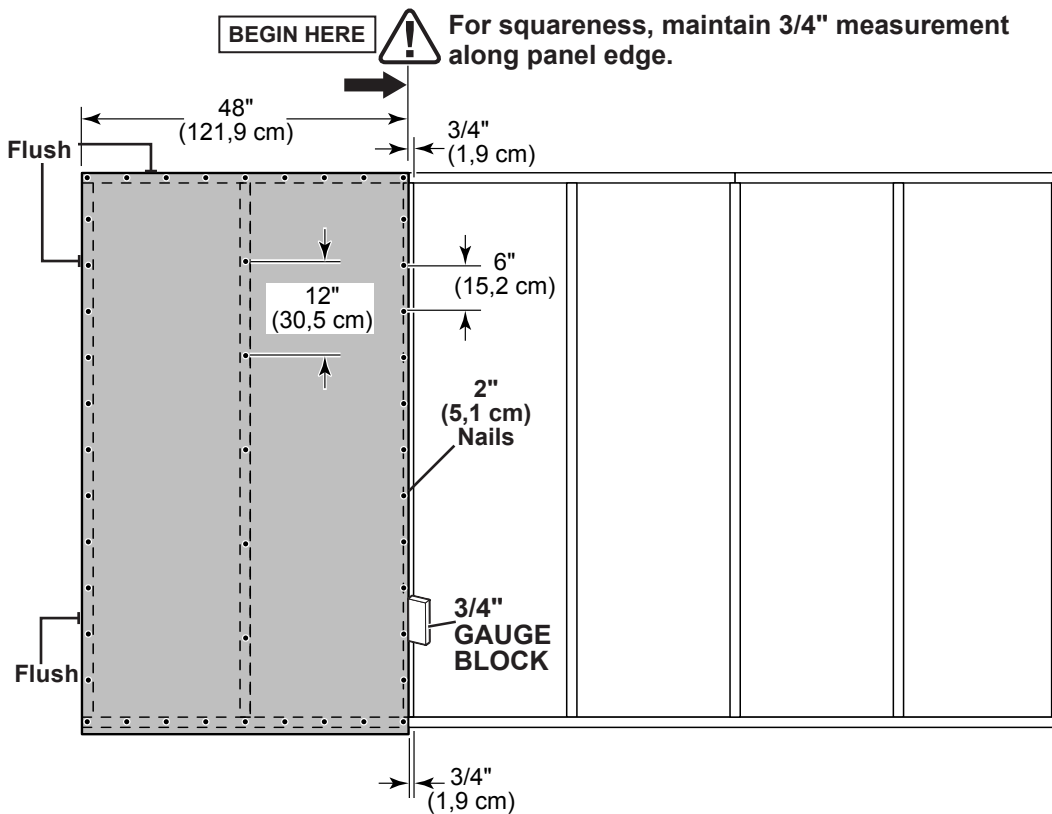

BACK WALL

PARTS REQUIRED:

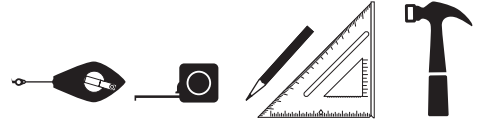
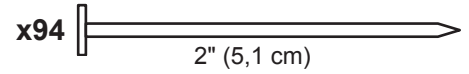
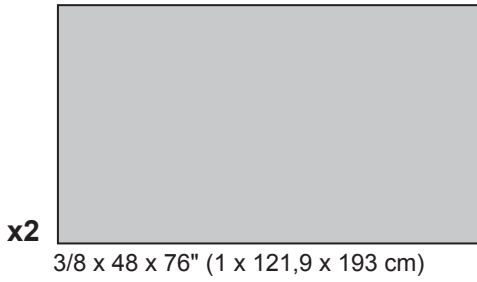

- 4** Install two more 48 x 76 panels on frame as shown (Fig. A).
Nail the panel using 2" nails 6" apart on edges and 12" apart inside panel.

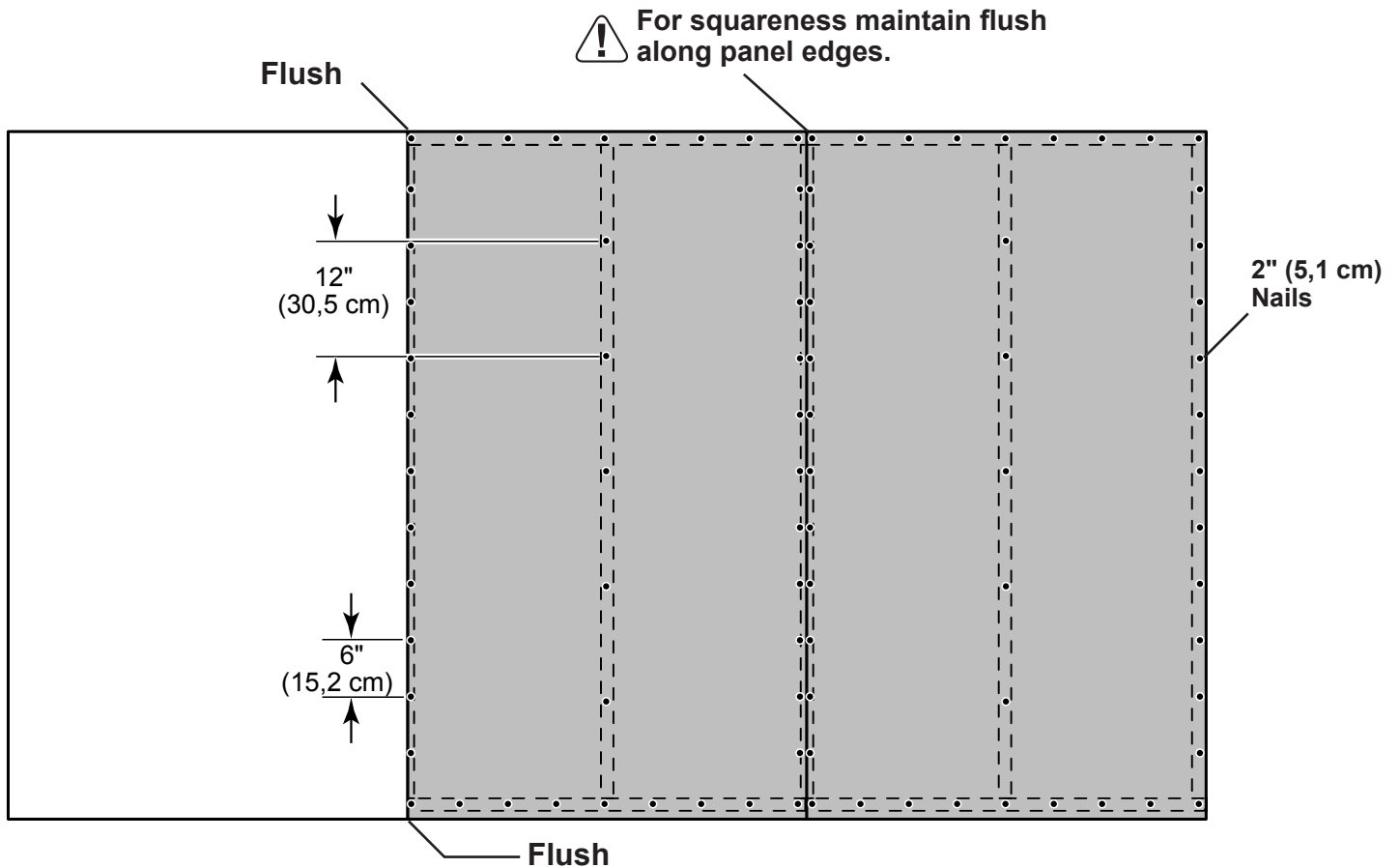

- 5** Carefully flip your back wall over.

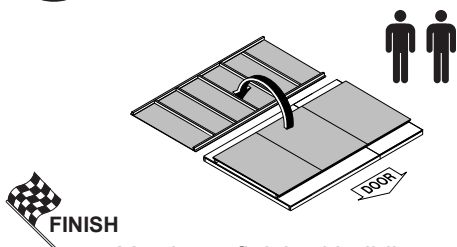

FRONT WALL (Door Header)

PARTS REQUIRED:

x2 **AM**
2 x 4 x 67" (5,1 x 10,2 x 170,2 cm)

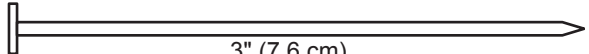
x18  3" (7,6 cm)

x1 
7/16 x 3-1/4 x 67" (1,1 x 8,3 x 170,2 cm) **OSB**

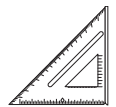

✓ BEGIN

- 1 Place (1) **AM** and **OSB** end-to-end on flat surface, flush in middle.
Center **OSB** on top of **AM**.

⚠ *Glue both sides of OSB.*

- 2 Nail using 3" nails in the pattern shown.

- 3 Flip header assembly over and nail as shown on the other side.

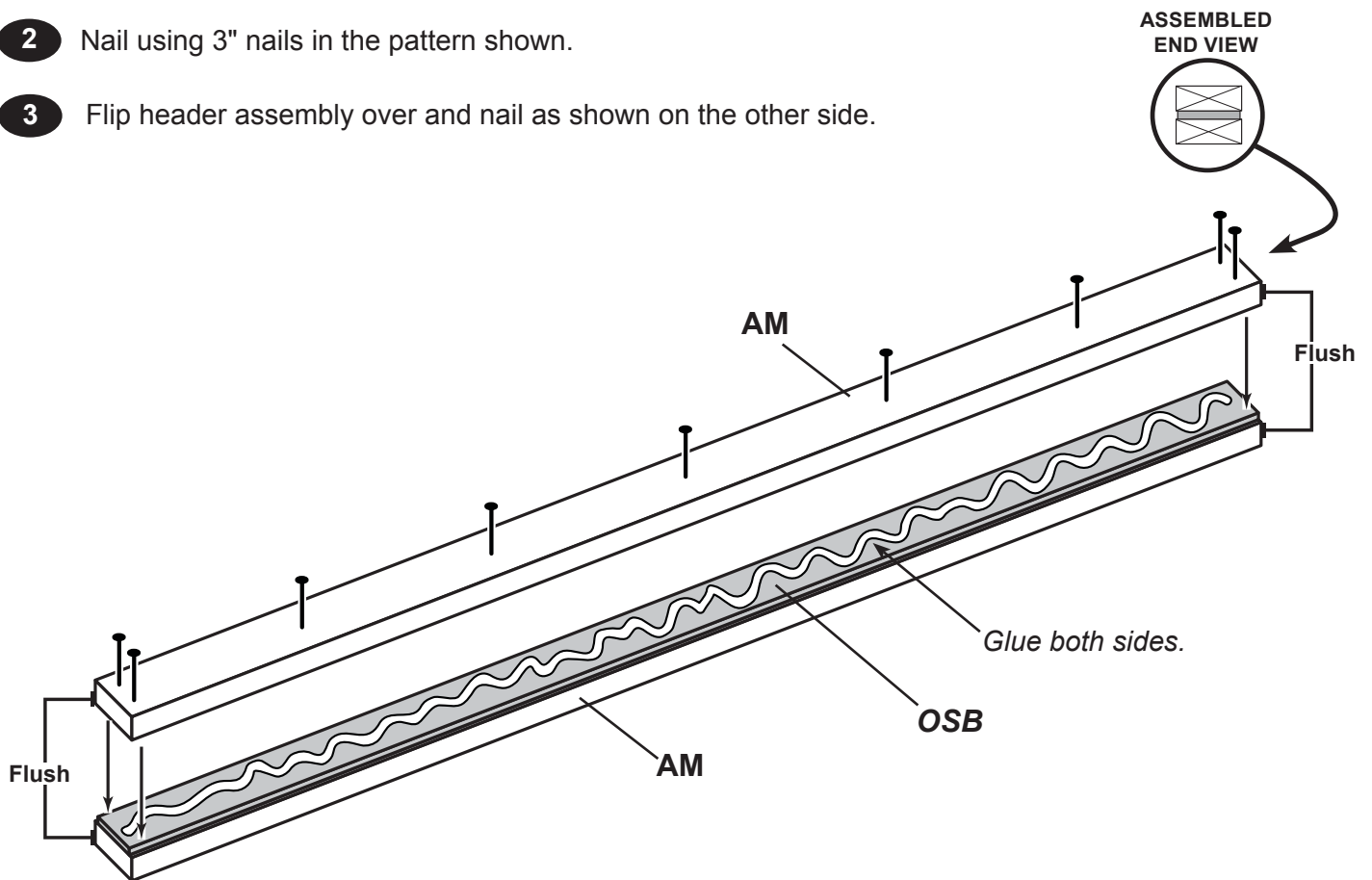





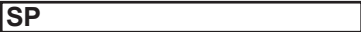

FINISH

You have assembled your door header.

FRONT WALL FRAME

PARTS REQUIRED:

- x1 **SP**  2 x 4 x 48" (5,1 x 10,2 x 121,9 cm)
- x1 **UX**  2 x 4 x 64" (5,1 x 10,2 x 162,6 cm)
- x2 **YFA**  2 x 4 x 68-1/2" (5,1 x 10,2 x 174 cm)
- x7 **TM**  2 x 4 x 72" (5,1 x 10,2 x 182,9 cm)
- x1 **TP**  2 x 4 x 96" (5,1 x 10,2 x 243,8 cm)
- Pre Assembled Header** 
- x1 **RB**  2 x 4 x 16" (5,1 x 10,2 x 40,6 cm)

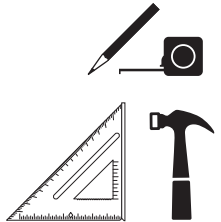
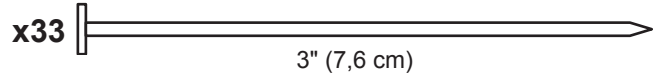

✓ BEGIN

- 1 Orient parts on edge on floor as shown. Measure and mark. Attach parts at marks using two 3" nails at each location and four 3" nails angled at seam as shown.



HINT:
For easier nailing stand on frame.

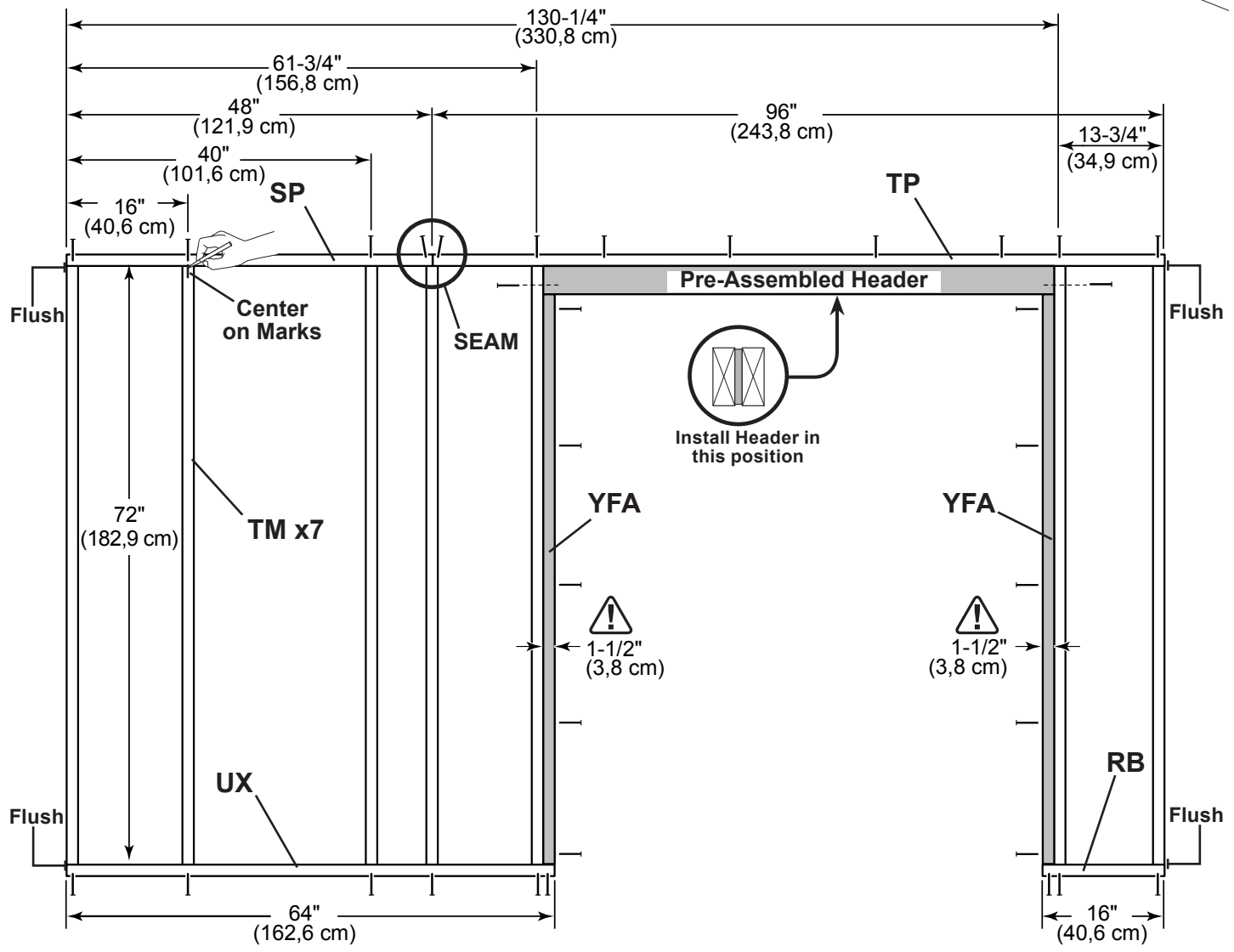
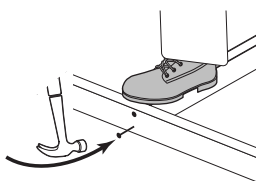

FINISH
You have finished building your front wall frame.

FRONT WALL

PARTS REQUIRED:

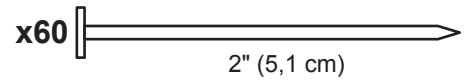

x1

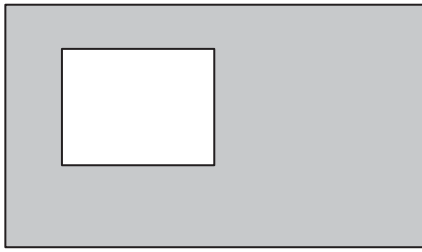

3/8 x 48 x 76" (1 x 121,9 x 193 cm)



✓ BEGIN

- 1 Place the 3/8 x 48 x 76" window panel onto wall frame as shown. Use the **GAA** gauge block to mark the 3/4" measurement on the wall stud.

Secure panel to frame with 2" nails 6" apart on edges and 12" apart inside panel.

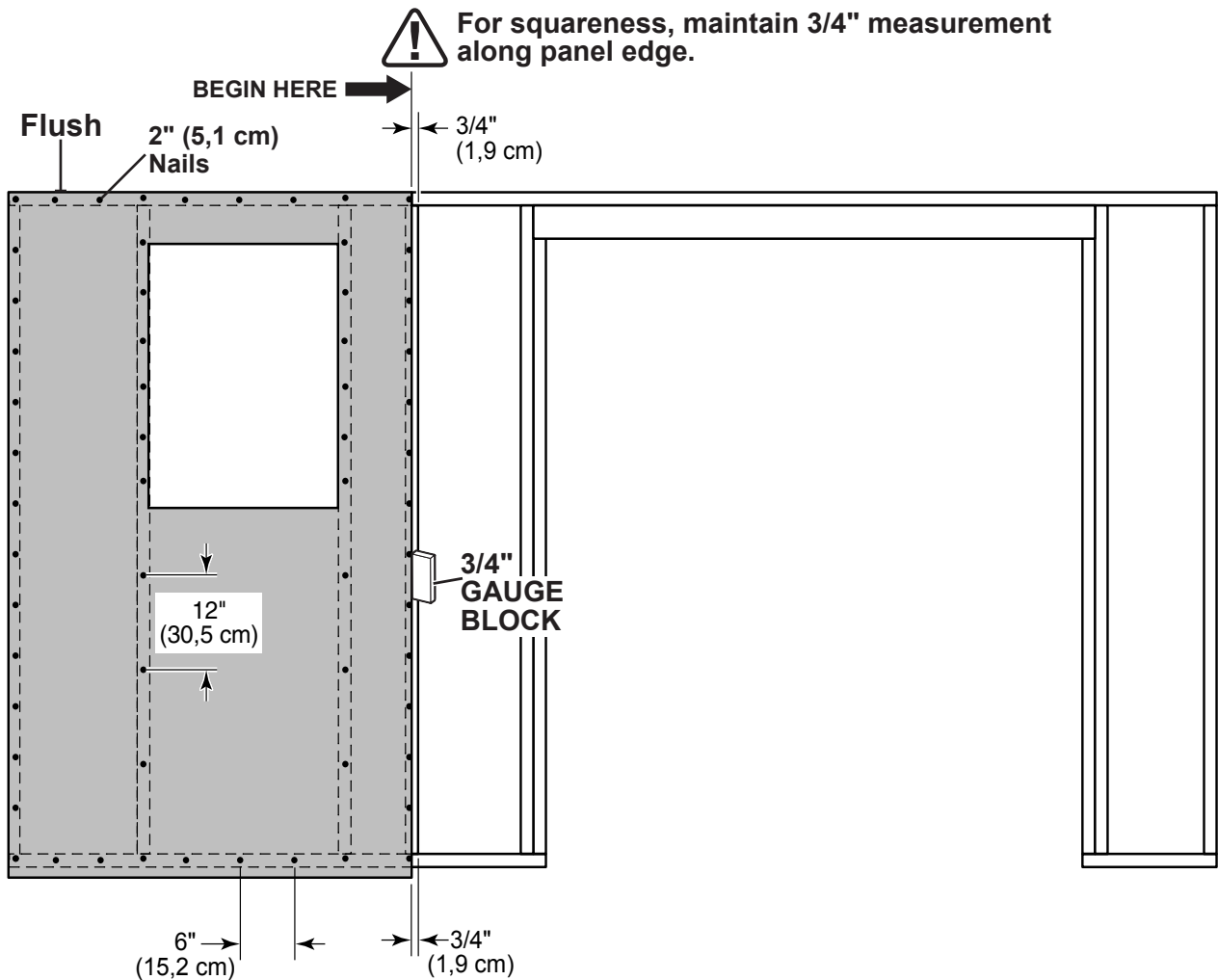

FRONT WALL

PARTS REQUIRED:

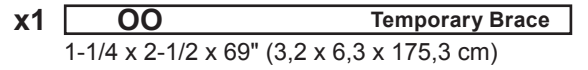
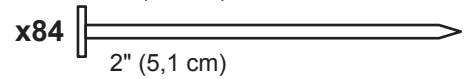
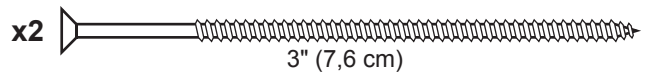
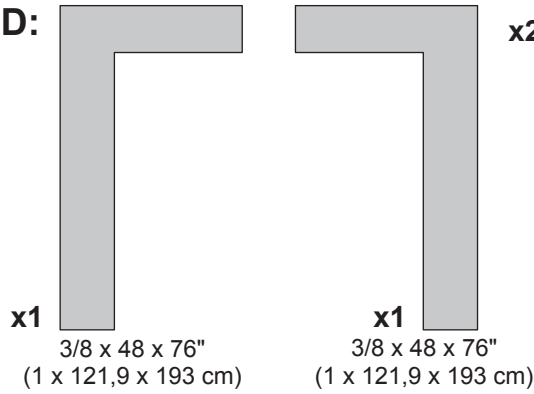

2 Place 3/8 x 48 x 76" door panels onto frame as shown. Secure panels to frame with 2" nails 6" apart on edges and 12" apart inside panel. Secure left panel first.

3 Hold a 64" opening using OO as temporary support. Secure OO using two 3" screws.

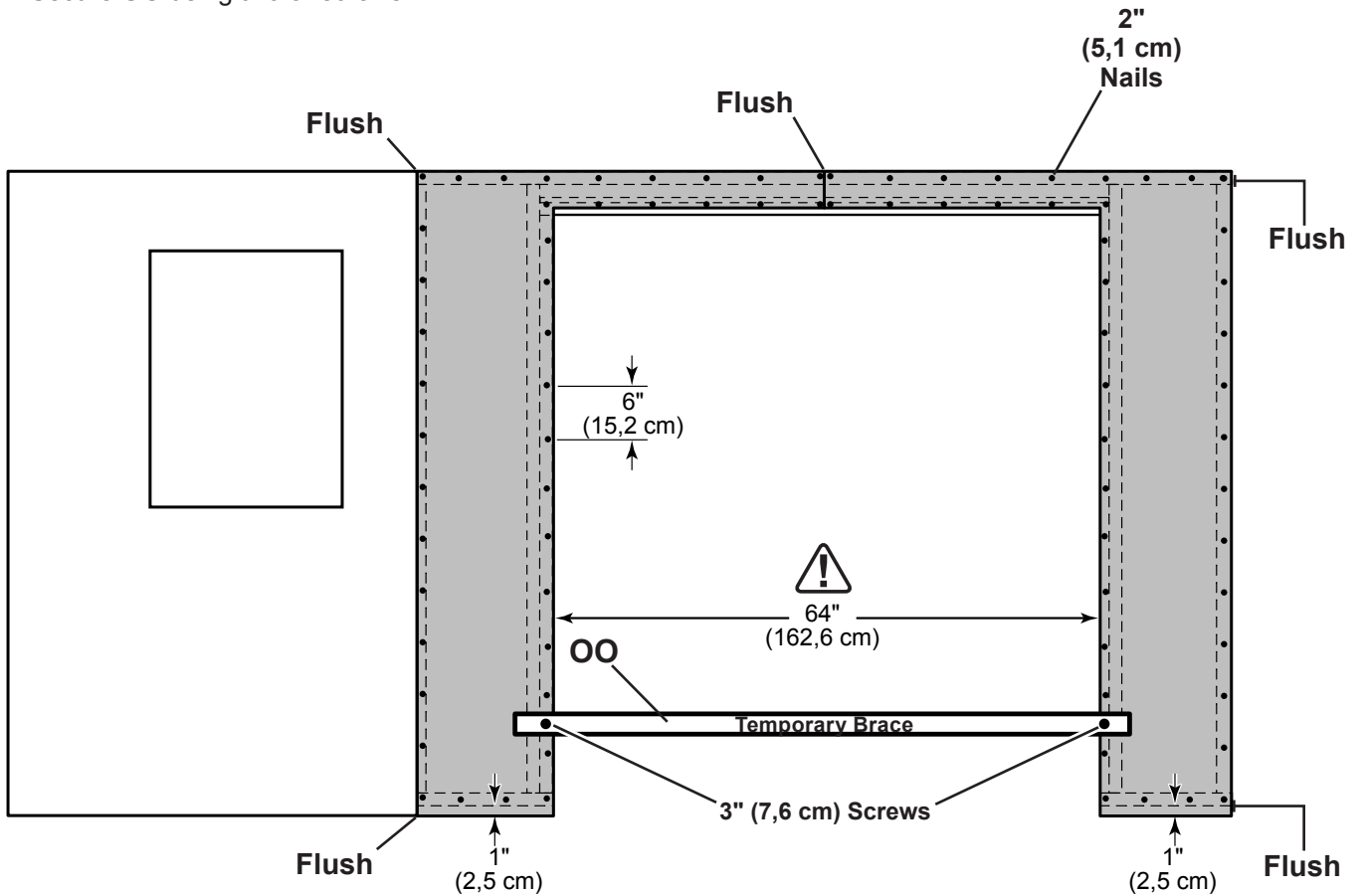

You have finished building your front wall.

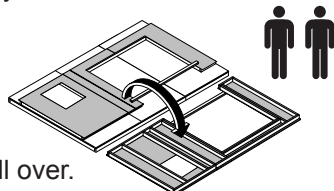

Carefully flip your front wall over.

GABLE WALLS

PARTS REQUIRED:

x10 **TM**
2 x 4 x 72" (5,1 x 10,2 x 182,9 cm)

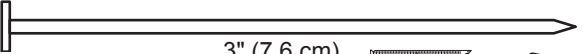
x40  3" (7,6 cm)

x4 **SZ**
2 x 4 x 89" (5,1 x 10,2 x 226,1 cm)

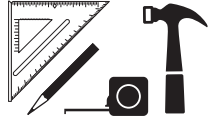

You will build 2 identical gable walls.

✓ **BEGIN**

1 Orient parts on edge on floor as shown. Measure and mark.

Secure parts using two 3" nails at each mark.

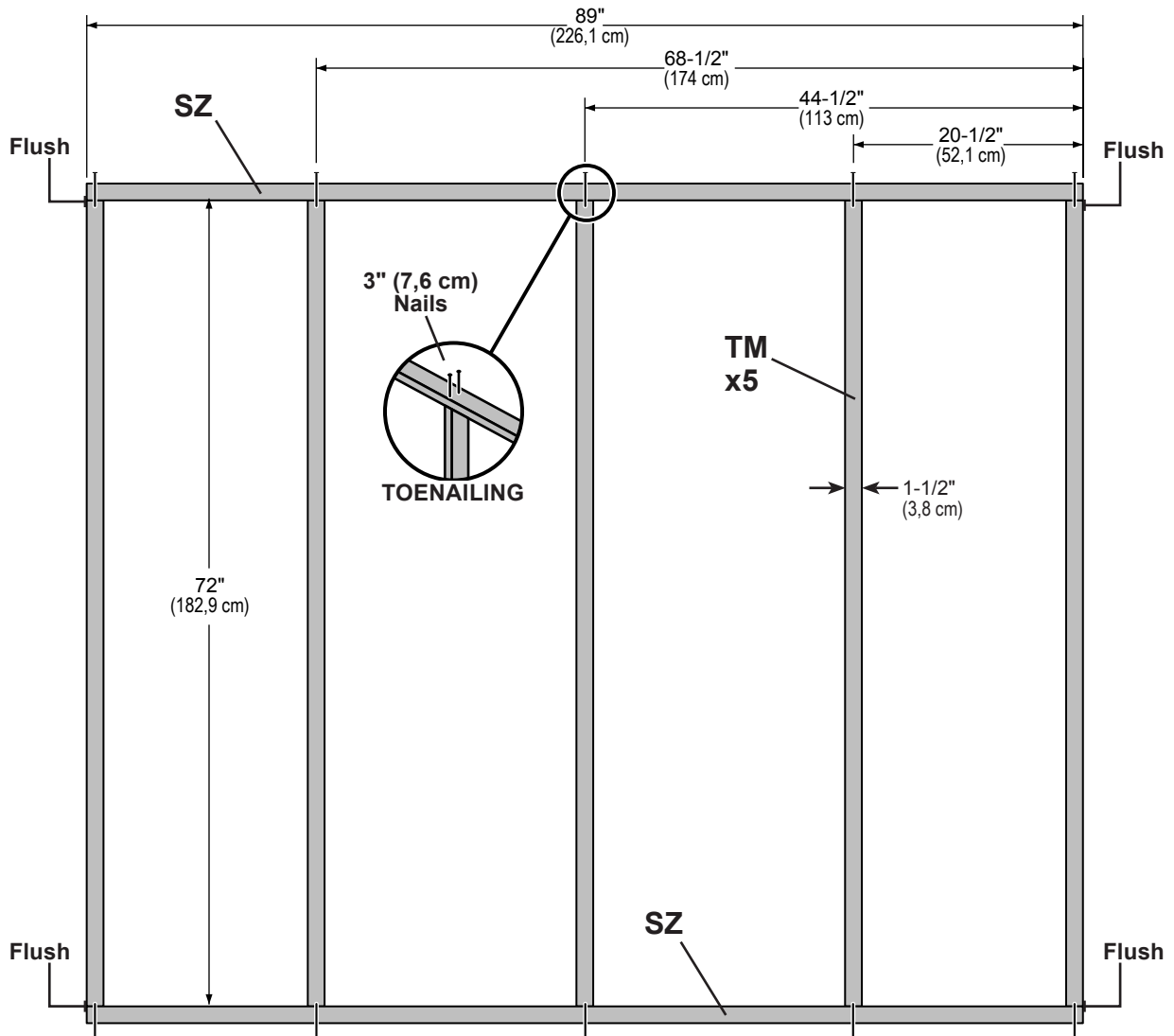

GABLE WALLS

PARTS REQUIRED:

x2 **ED**
2 x 3 x 26" (5,1 x 7,6 x 66 cm)

x5 **GUSSET**

x4 3" (7,6 cm)

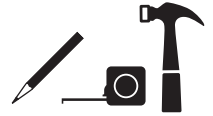

- Center gable connector **ED** over middle stud and flush to top plate.
Support **ED** using (5) **gussets** as shown.
Secure **ED** to top of top plate using (2) 3" nails, toenailed as shown.

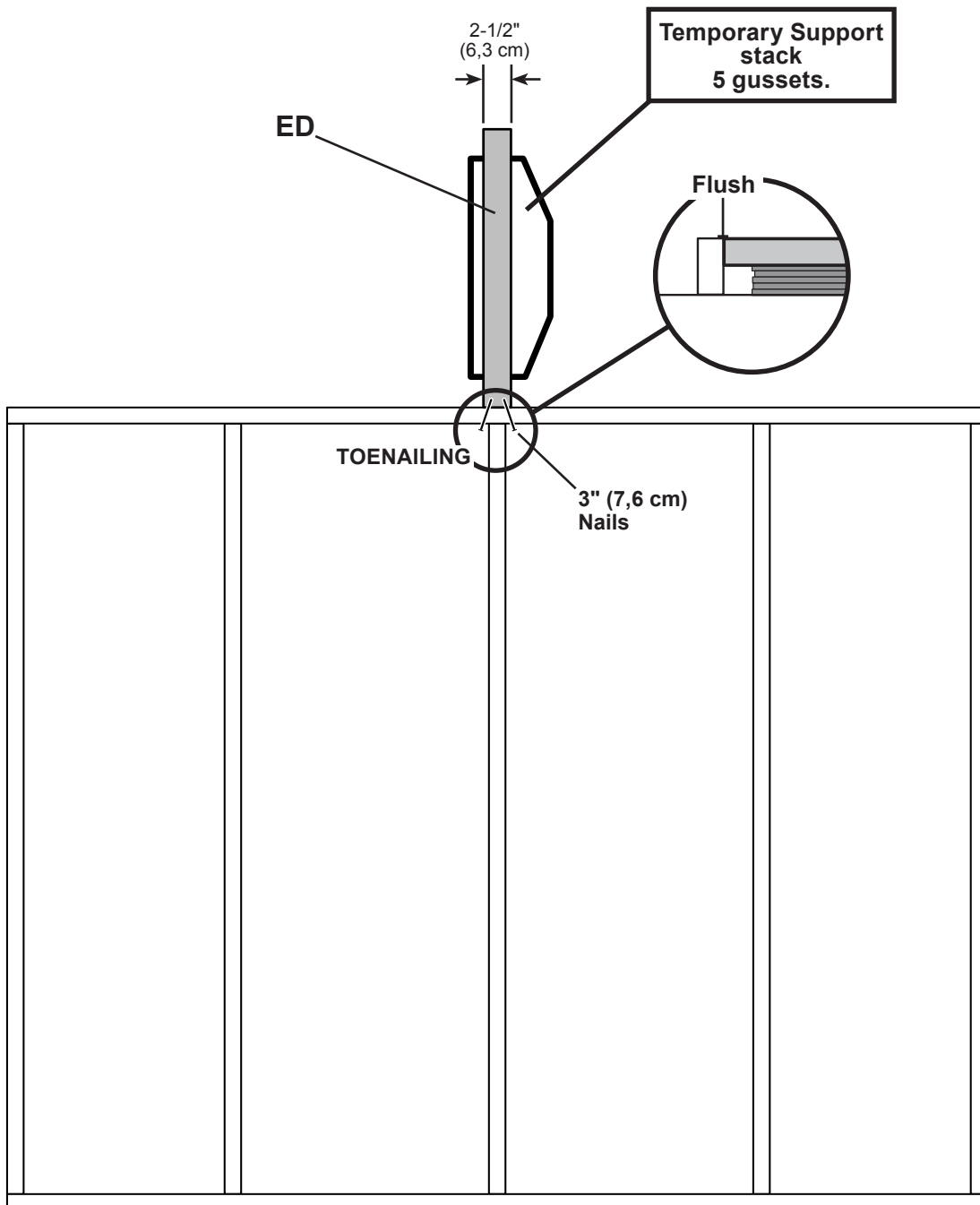

GABLE WALL PANELS

PARTS REQUIRED:

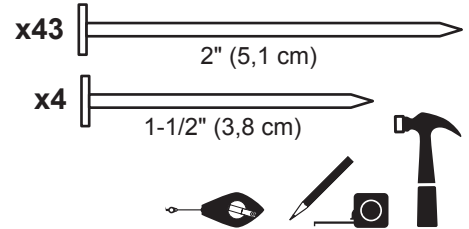
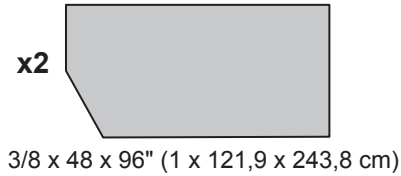

- Place left 48 x 96" gable wall panel onto wall frame as shown. **Panel overhangs frame 1" at bottom.**
Use the **GAA** gauge block to maintain the 3/4" measurement on the wall stud.
Secure panel to frame using 2" nails 6" apart on edges and 12" apart inside panel.
Secure panel to **ED** using 1-1/2" nails 6" apart.

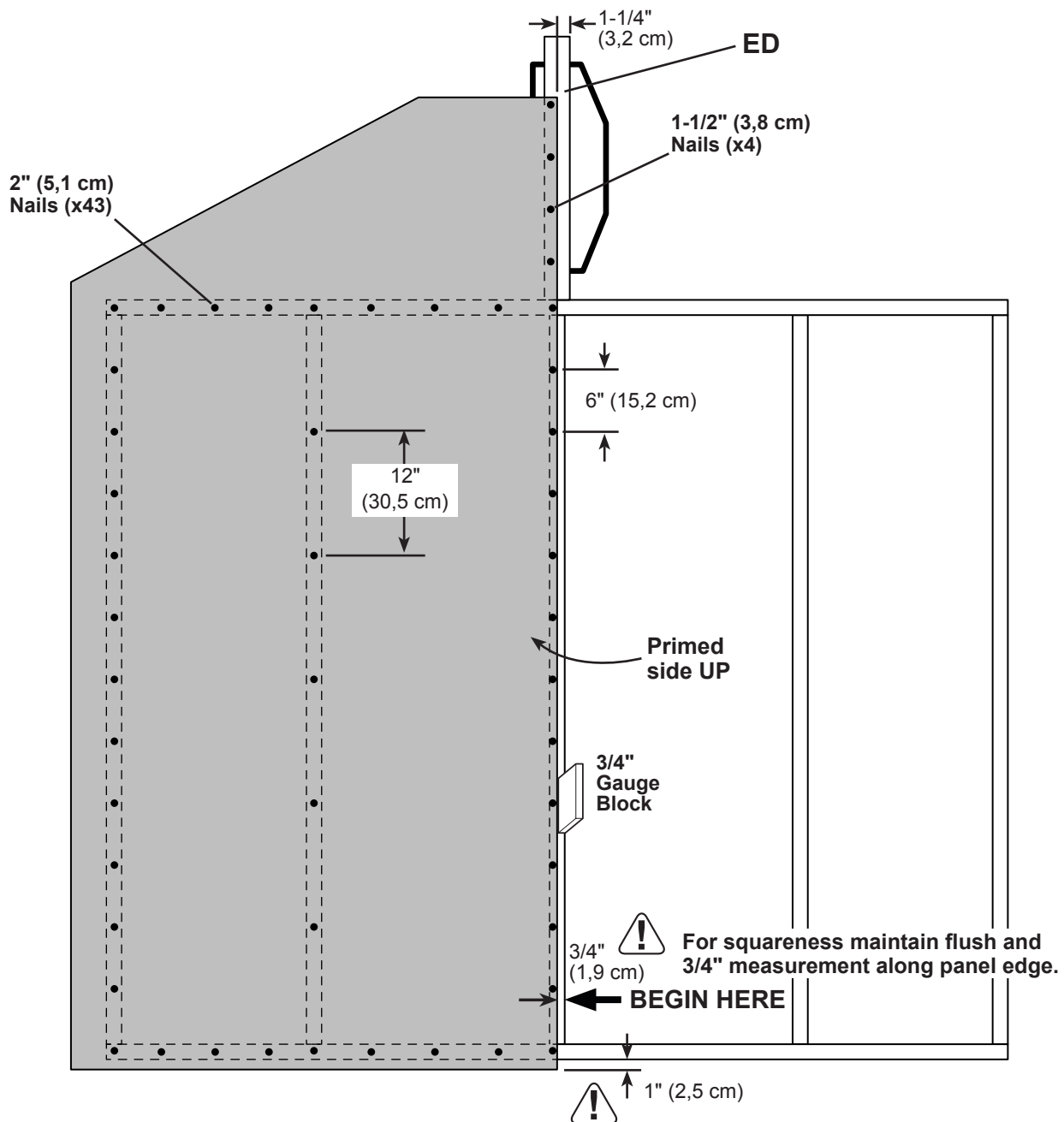

GABLE WALL PANELS

PARTS REQUIRED:

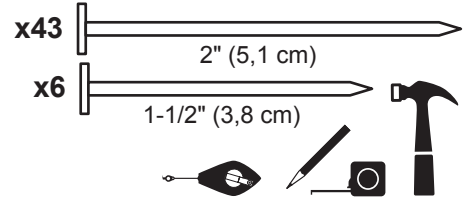
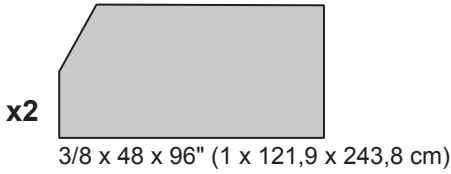

- 4** Place panels flush to installed panel as shown. **Panel overhangs frame 1" at bottom.**
 Secure **48" x 96"** panel to frame using 2" nails 6" apart on edges and 12" apart inside panel.
 Secure **large** top panel to gable connector **ED** using 1-1/2" nails as shown.

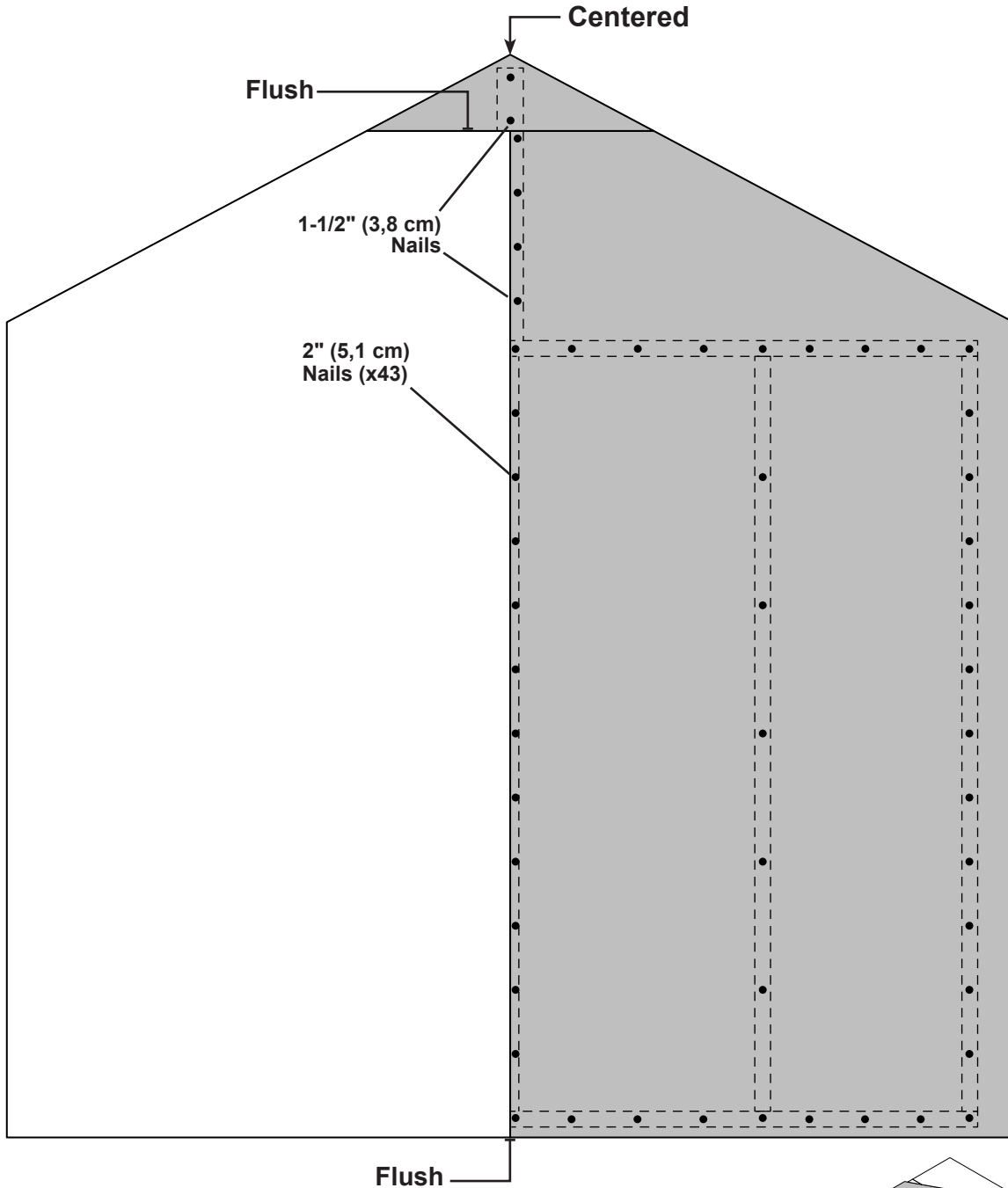

Repeat STEPS 1 - 4 to build your second gable wall.

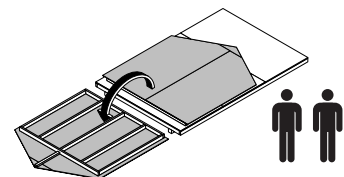

BACK WALL

PARTS REQUIRED:

x1 **OO**
1-1/4 x 2-1/2 x 69" (3,2 x 6,3 x 175,3 cm)



x12 3" (7,6 cm)
x2 3" (7,6 cm)
x27 2" (5,1 cm)

✓ **BEGIN**

1 Center back wall on the 144" (365,8 cm) floor dimension.

Use **OO** as a temporary brace.
Secure with two 3" screws.

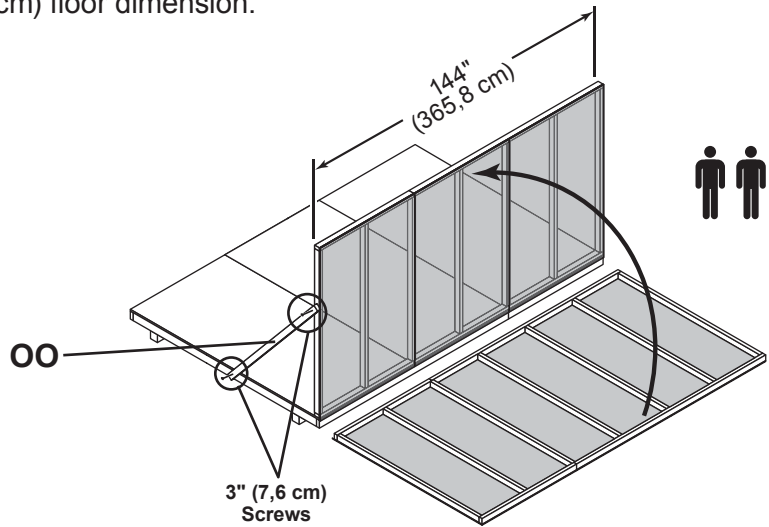

2 First, nail lower edge of panel to floor frame using 2" nails 6" apart. Angle nail to hit floor frame (**Fig. A**).

3 Secure wall bottom plates to floor using 3" nails (**Fig. A**).

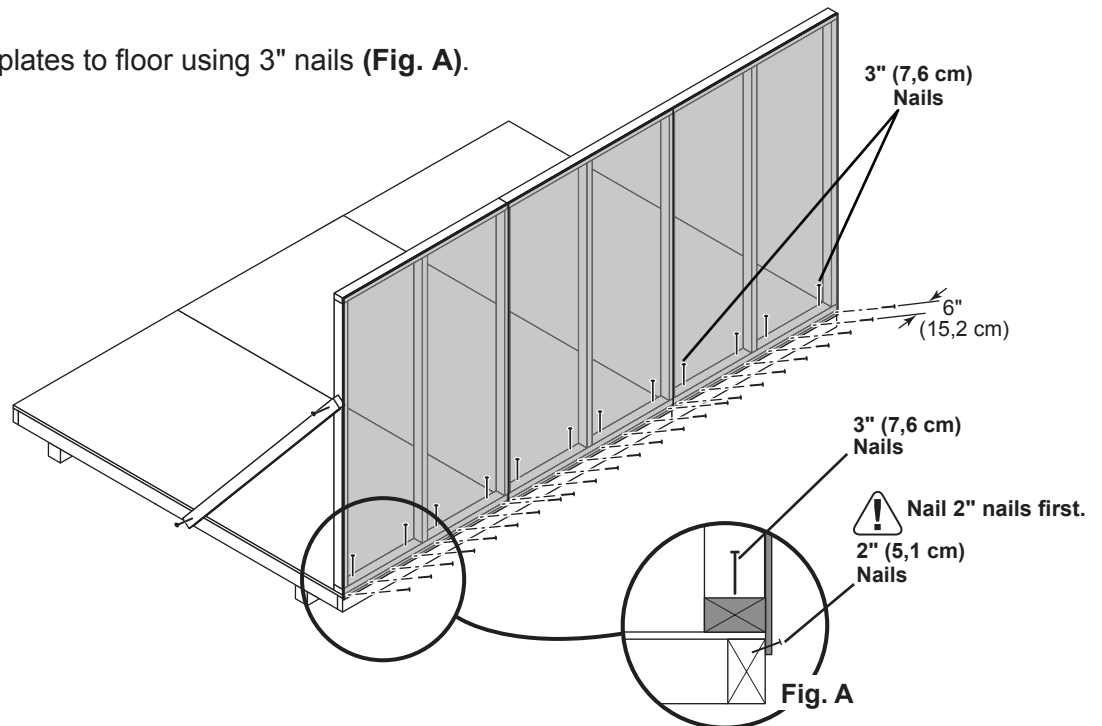

You have finished standing your back wall.

LEFT WALL

PARTS REQUIRED

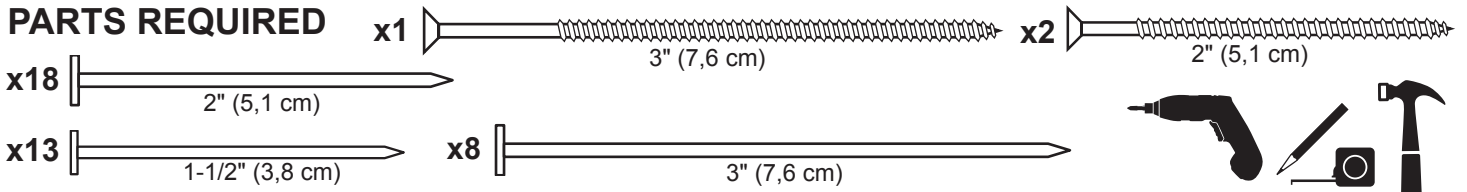

✓ BEGIN

1 Place left wall centered on floor.

Secure wall using one 2" screw into back wall bottom plate (**Fig. A**) and top plate (**Fig. B**).

Secure wall to bottom plate first.

⚠ ENSURE PANEL CORNERS ARE FLUSH. ⚠

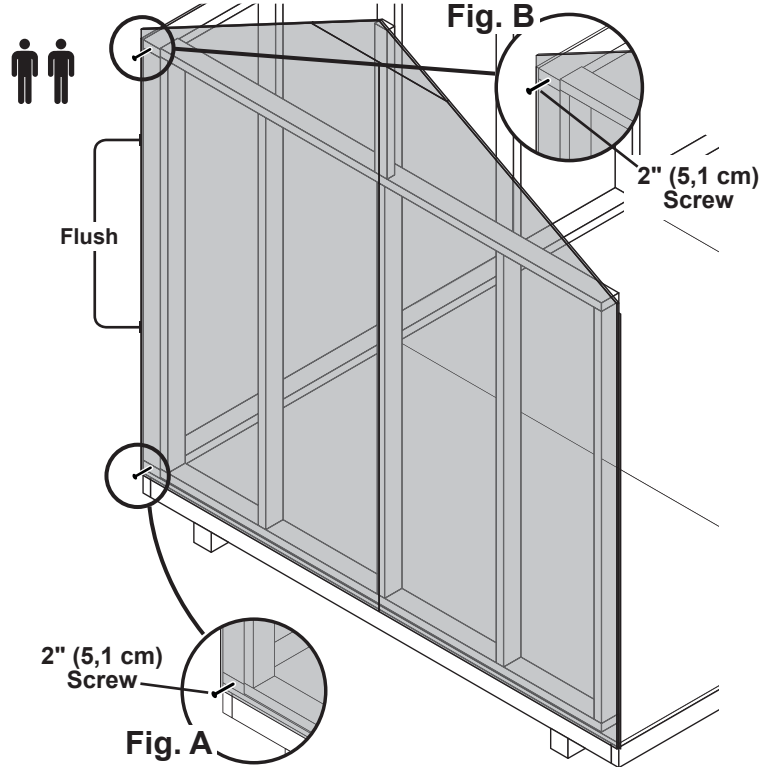

2 Nail lower edge of panels to floor using 2" nails 6" apart. Angle nail to hit floor frame (**Fig. C**).

Nail panels to back wall stud using 1-1/2" nails.

3 Secure wall top plates using a 3" screw toe-screwed at the corner at an angle as shown in (**Fig. D**).

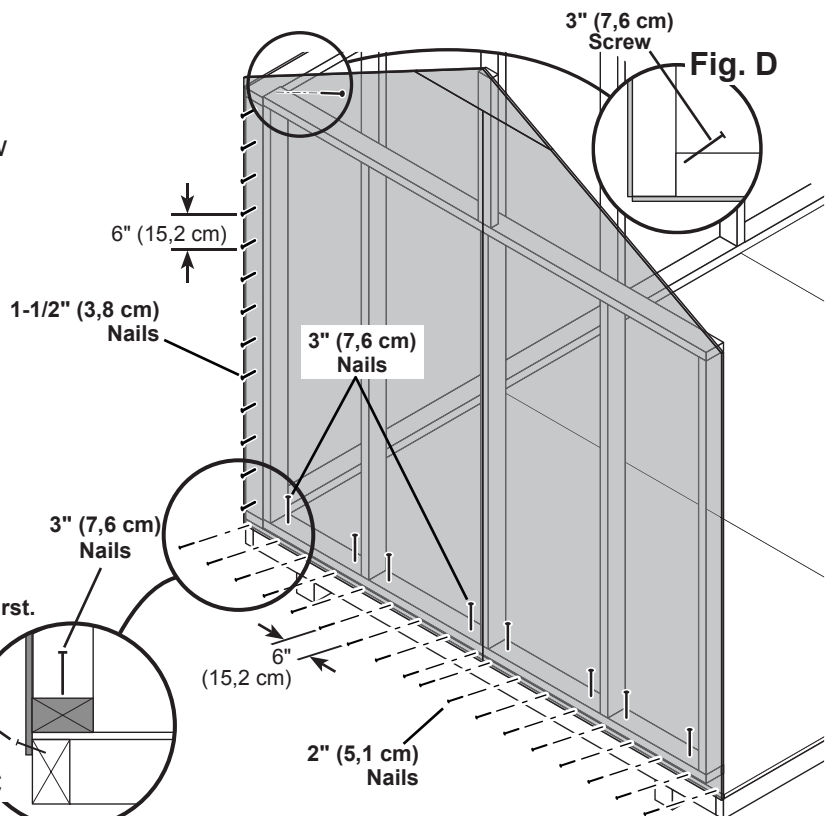

FINISH

Your left wall is now installed.

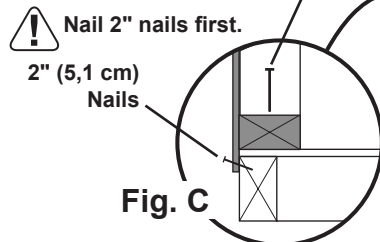



FRONT WALL

PARTS REQUIRED:

x1 **PT**
2 x 3 x 96" (5,1 x 7,6 x 243,8 cm)

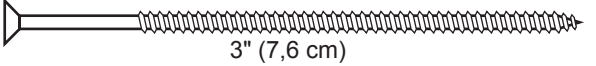

x2  3" (7,6 cm)

x2  2" (5,1 cm)

✓ **BEGIN**

1 Center front wall on the 144" (365,8 cm) floor dimension.

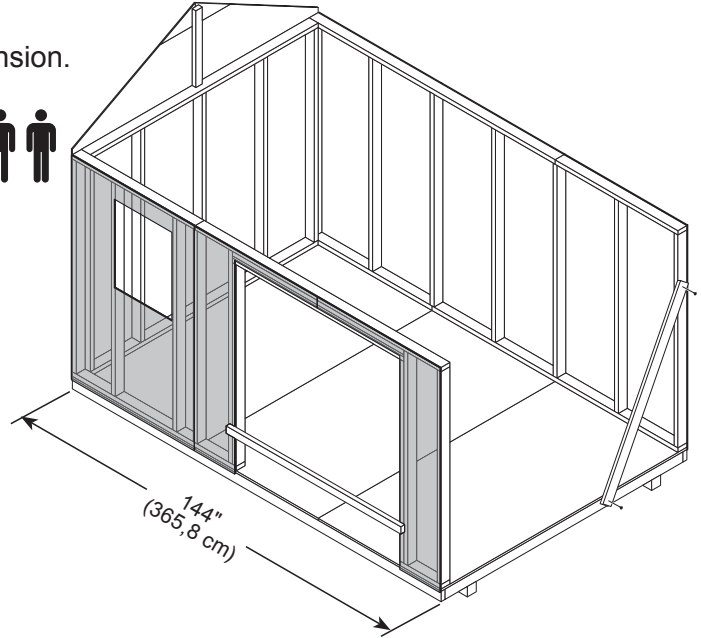

Secure wall using one 2" screw through left wall panel into front wall bottom and top plates (**Fig. B, Fig. A**).

Secure wall to bottom plate first.

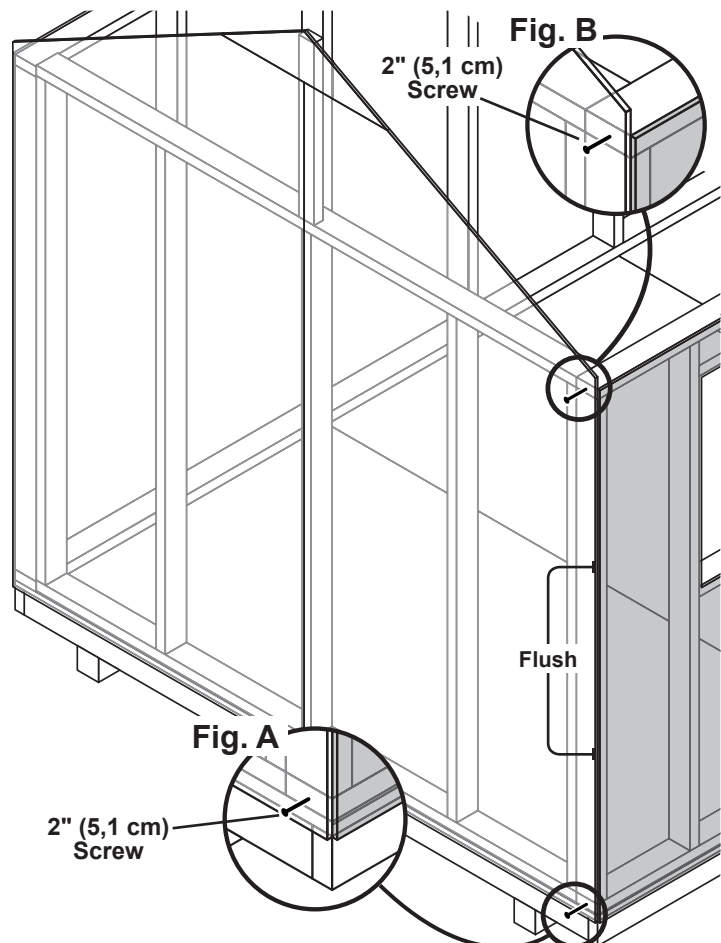

 **ENSURE PANEL CORNERS ARE FLUSH.** 

2" (5,1 cm) Screw

FRONT WALL

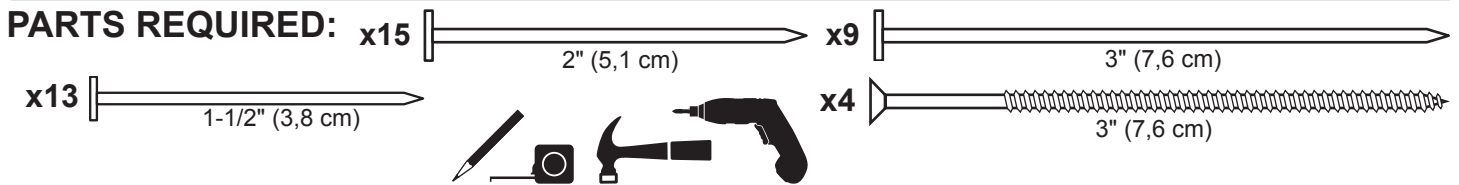

- 3** Nail lower edge of front wall panels to floor frame using 2" nails 6" apart. Angle nail to hit floor frame (**Fig. C**).

Secure front wall bottom plates to floor using 3" nails (**Fig. C**).

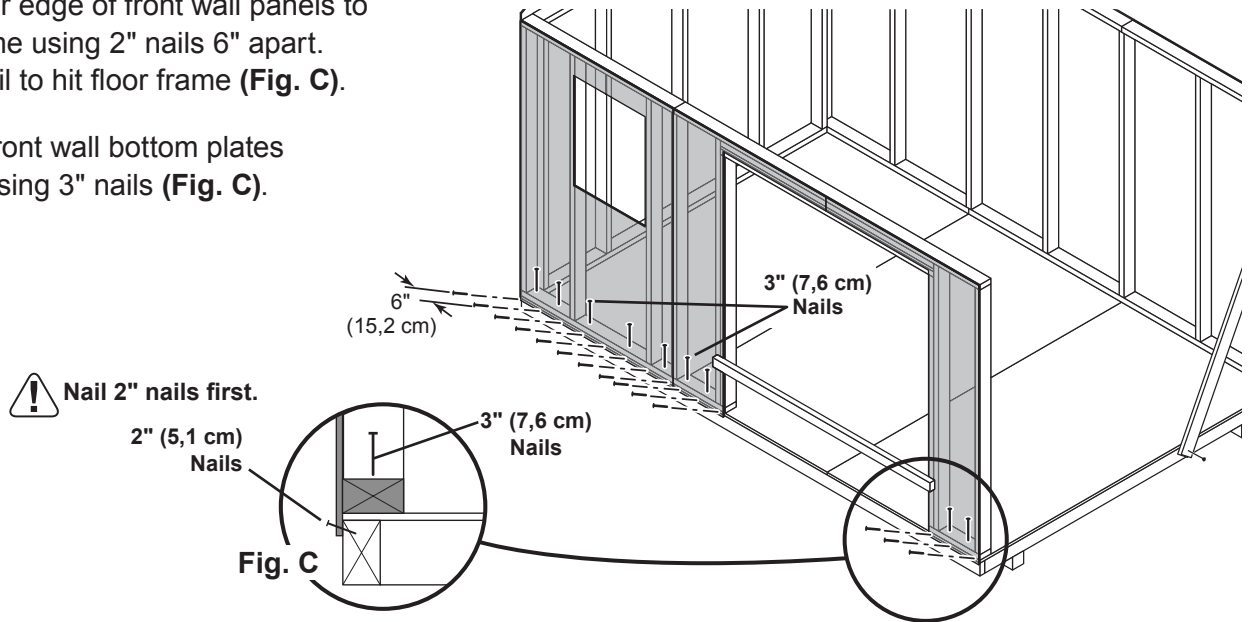

- 4** Nail left wall panel to front wall stud using 1-1/2" nails 6" apart.

- 5** Secure wall top plates using 3" screws toe-screwed at each corner at an angle as shown in (**Fig. D**).

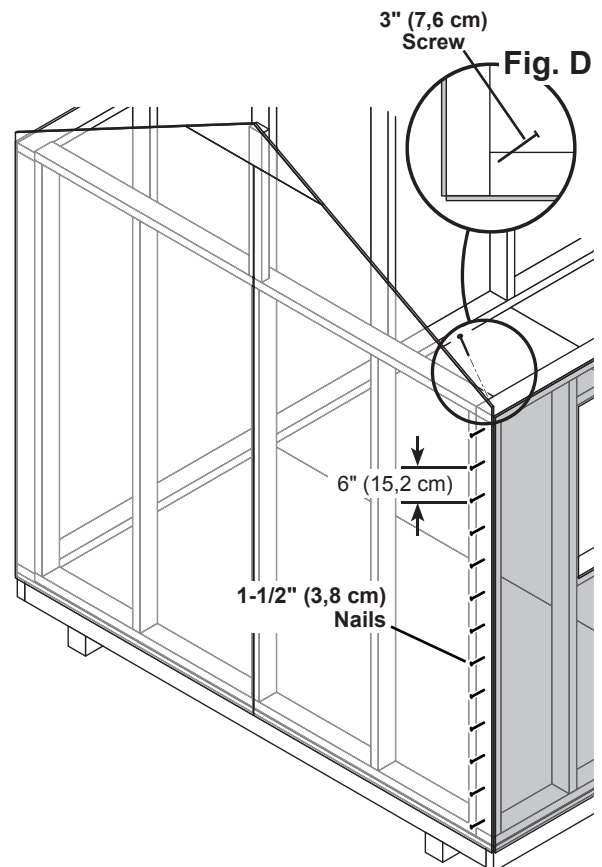

Your front wall is now installed.

RIGHT WALL

PARTS REQUIRED

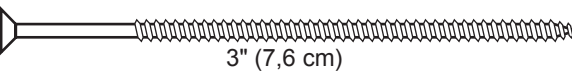
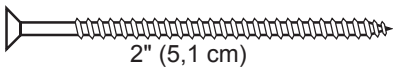
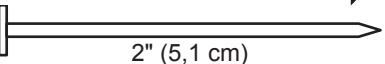
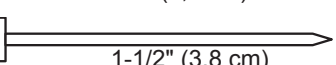
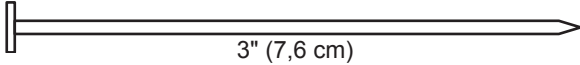
- x2  x4 
- x18 
- x26  x8 

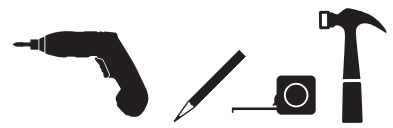

REMOVE TEMPORARY BRACING

✓ BEGIN

- 1 Place right wall on floor centered between front and back walls.

Secure wall using 2" screws into top and bottom plates (**Fig. A, Fig. B**).

Secure wall to bottom plate first.

⚠ ENSURE PANEL CORNERS ARE FLUSH. ⚠

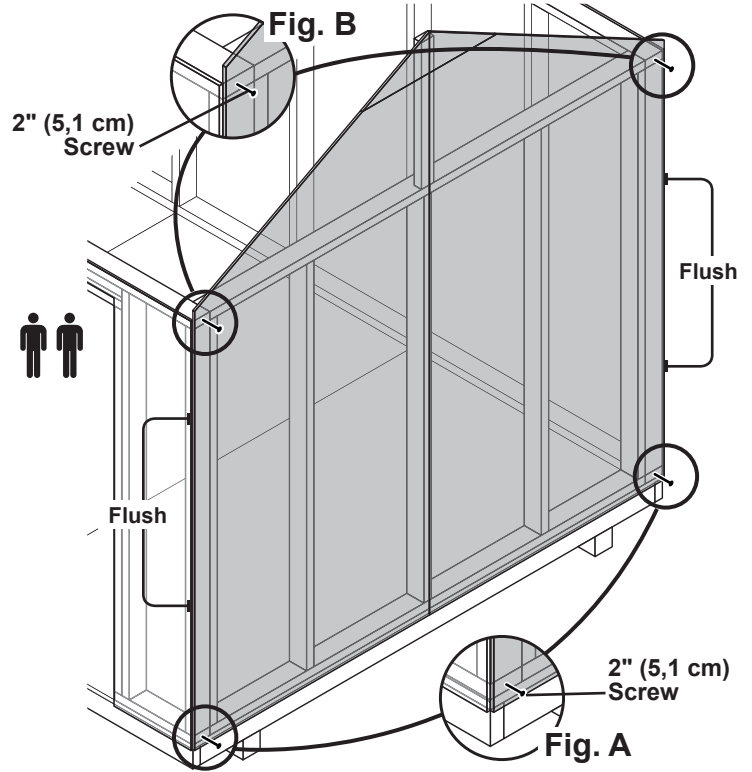

- 2 Nail lower edge of panels to floor using 2" nails 6" apart. Angle nail to hit floor frame (**Fig. C**).

Nail panels to front and back wall studs using 1-1/2" nails.

- 3 Secure wall top plates using 3" screws toe-screwed at each corner at an angle as shown in (**Fig. D**).

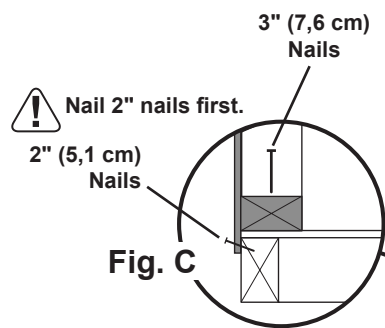
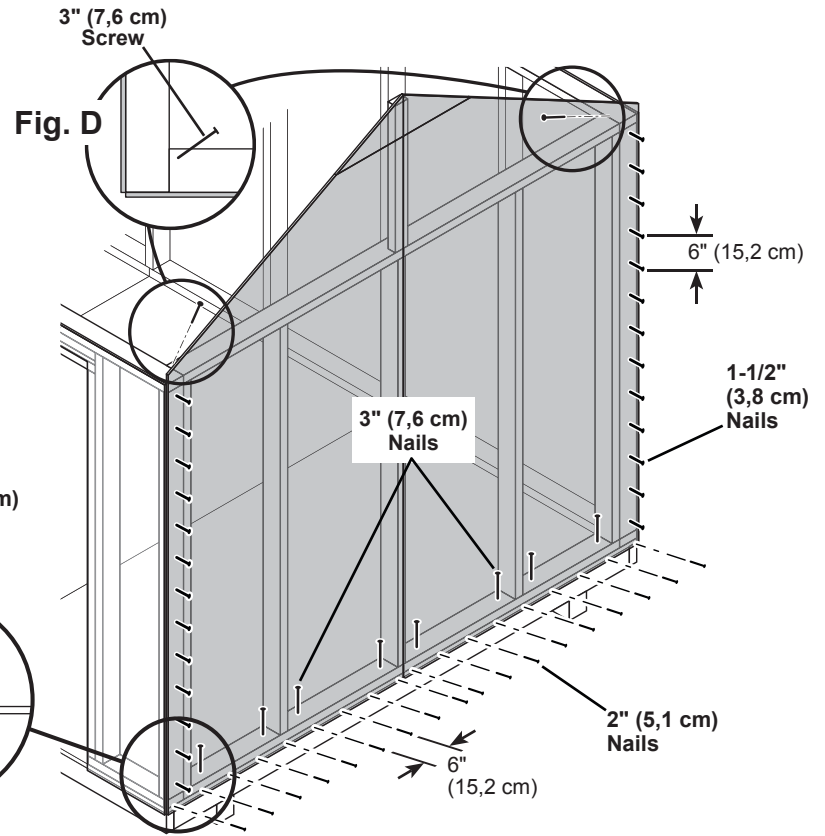

Your right wall is now installed.

EAVE WALL SQUARING

PARTS REQUIRED:

x2 **TP** Temporary Brace
2 x 4 x 96" (5,1 x 10,2 x 243,8 cm)



x5

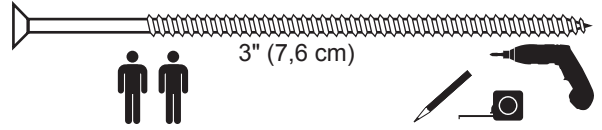

3" (7,6 cm)

✓ BEGIN

- 1 Place **TP** flush under top plates at the back wall's 3rd stud and the front wall's 4th stud. Fit **TP** with edges flush to front and back panels using (3) 3" screws as shown (**Fig. A, Fig. C**). Secure **TP** to studs each end using 3" screws (**Fig. A**).
- 2 Measure from end of brace (inside wall panel) 27-3/4" and mark a vertical line on brace (**Fig. A and B**).
- 3 Locate a **TP** diagonally in the position shown (**Fig. A**) and attach at lower end with one 3" screw. With assistance, push or pull the wall until diagonal **TP** is flush to the mark and to top of brace (**Fig. A, B and C**). Secure **TP** to brace (**Fig. B**) using (2) 3" screws.

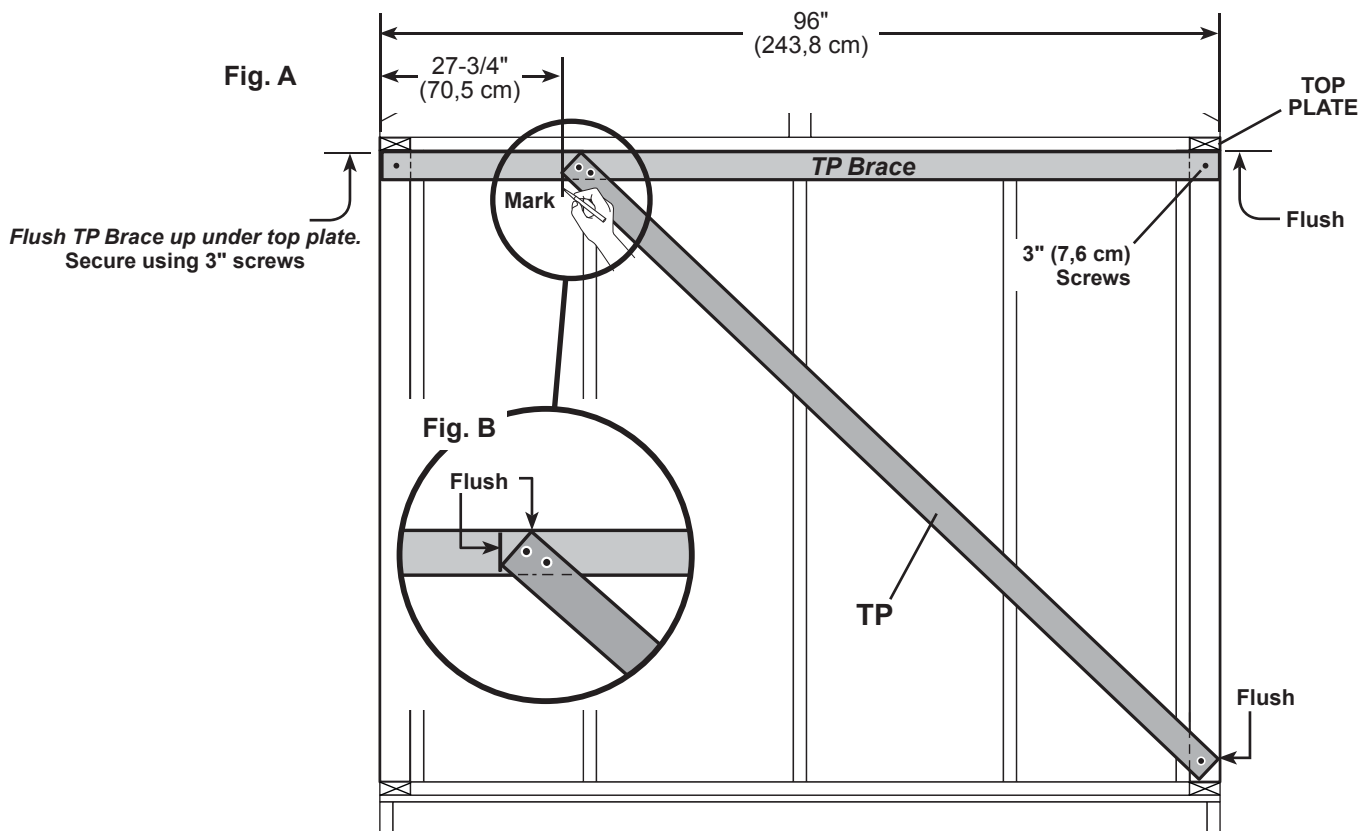

HINT:

Leave your temporary brace in place until you finish attaching your roof panels.

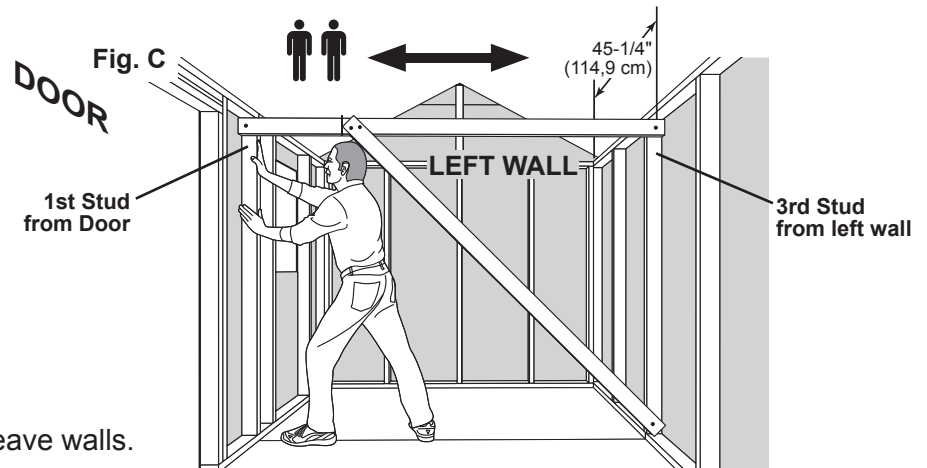

FINISH

You have finished squaring your eave walls.

WINDOW FRAME

PARTS REQUIRED:

x1 **PU**
2 x 4 x 3-1/2" (5,1 x 10,2 x 8,9 cm)

x2 **LV**
2 x 4 x 22-1/2" (5,1 x 10,2 x 57,2 cm)

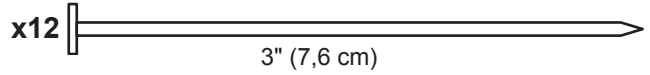

✓ BEGIN

- 1 Place **PU** at measurement show flush under top plate.
Secure using two 3" nails.
- 2 Place **AO** flush to window opening as shown.
Secure using two 3" nails at each connection.

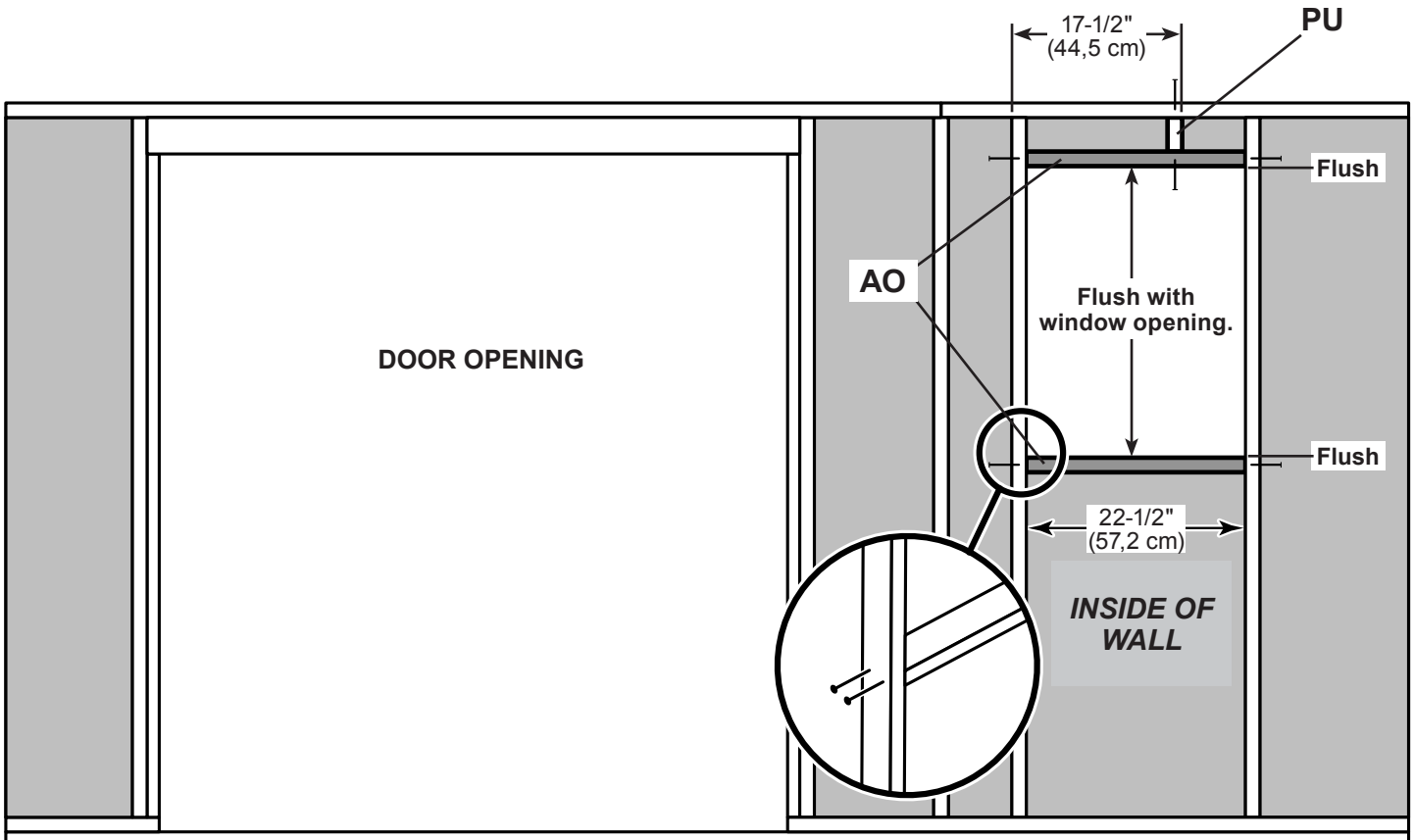

Your window framing is now complete.

SHELF

PARTS REQUIRED:

x5 **AE**

2 x 3 x 10-1/8" (5,1 x 7,6 x 25,7 cm)

x5



3/8 x 8 x 12-1/2" (1 x 20,3 x 31,8 cm)

x15

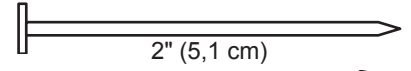

2" (5,1 cm)



✓ **BEGIN**

- 1 Secure **AE** to bracket panels using three 2" (5,1 cm) nails.
Assemble 5 shelf supports as shown; 4 right-side, 1 left-side.

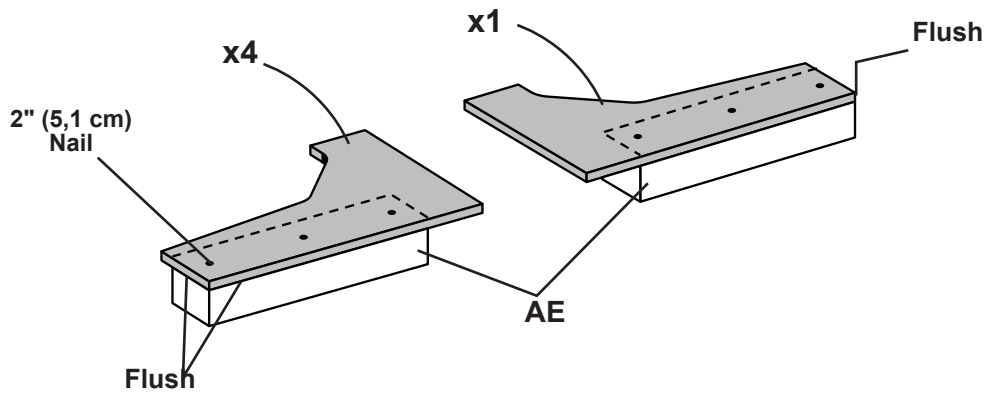

- 2 Secure shelf supports at shown height with three 2" (5,1 cm) nails.

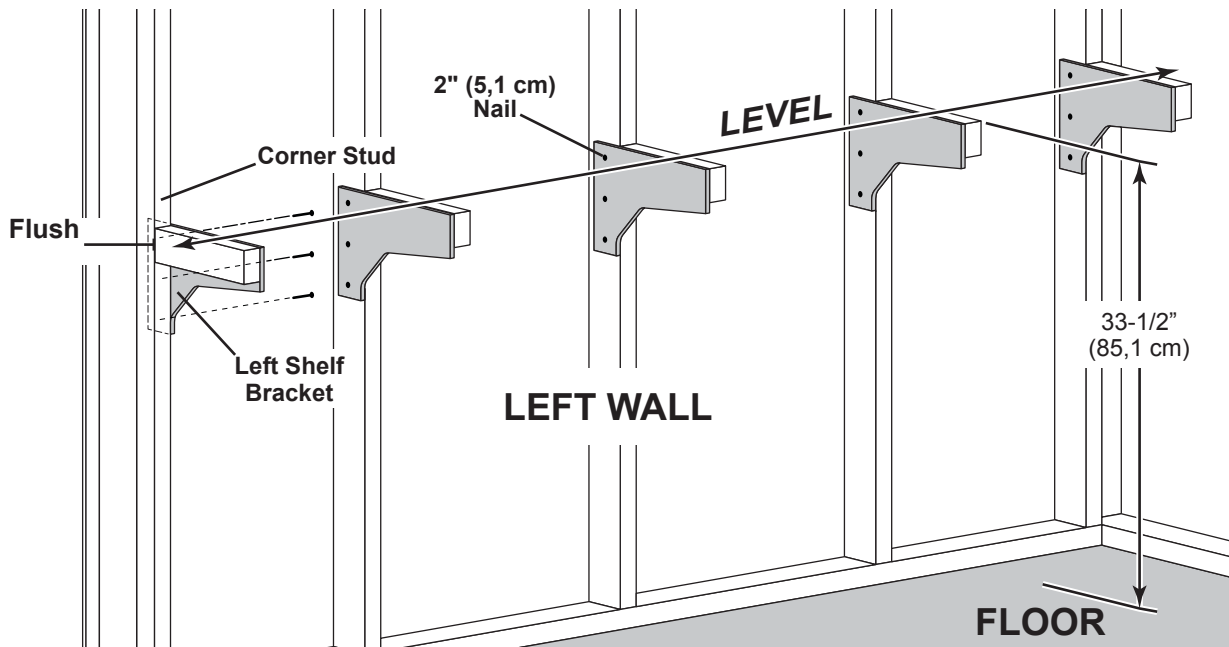

SHELF

PARTS REQUIRED:

x1



7/16 x 11-3/4 x 96" (1,1 x 29,8 x 243,8 cm)

x1

KP

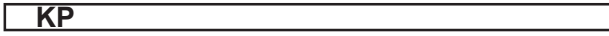

1 x 4 x 96" (2,5 x 10,2 x 243,8 cm)

x20 2" (5,1 cm)



- 3** Install shelf panels centered over shelf supports. Secure with two 2" (5,1 cm) nails at each support.

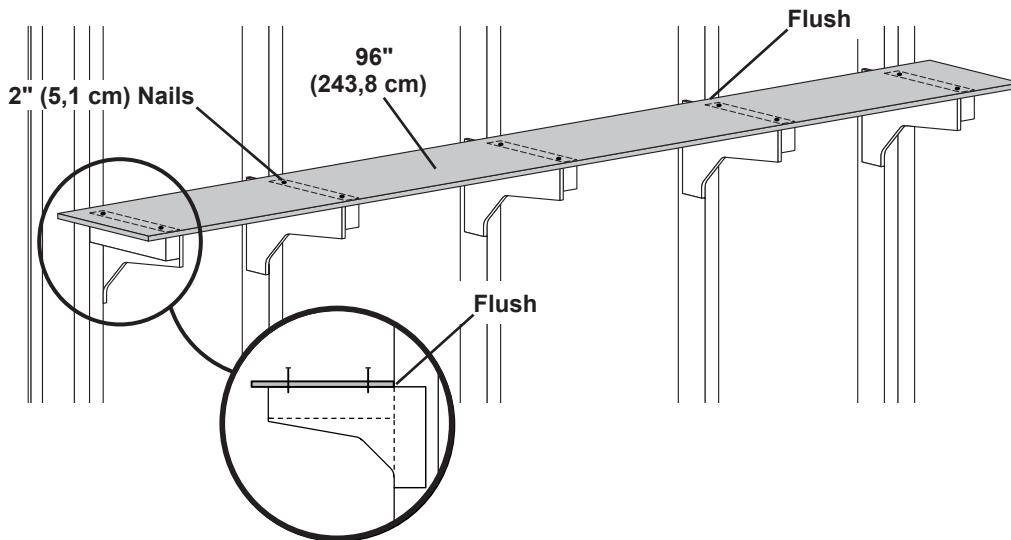

- 4** Secure **KP** with two 2" (5,1 cm) nails at each support as shown.

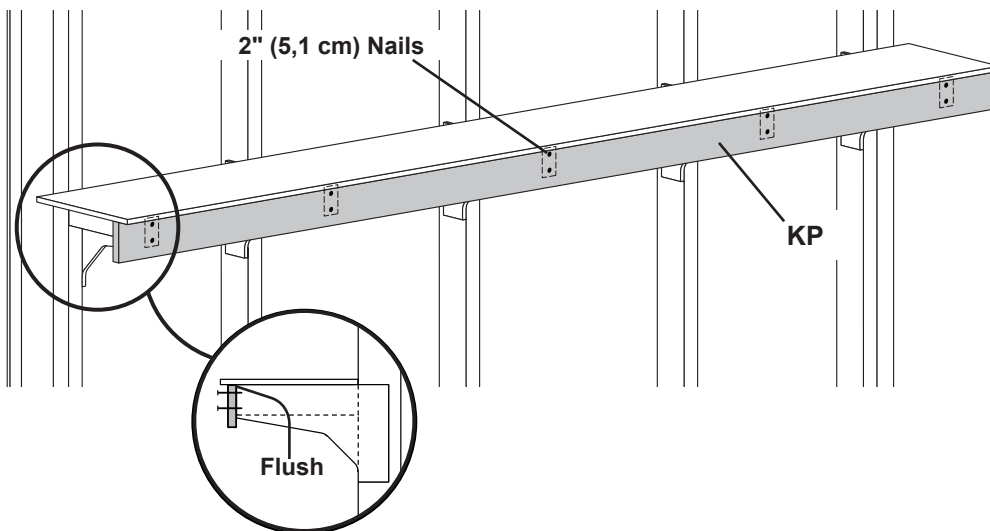

Your shelf is now installed.

LOFT

PARTS REQUIRED:

x1 **PT**
2 x 3 x 96" (5,1 x 7,6 x 243,8 cm)

x1 **TP**
2 x 4 x 96" (5,1 x 10,2 x 243,8 cm)

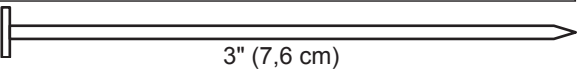
x5  3" (7,6 cm)

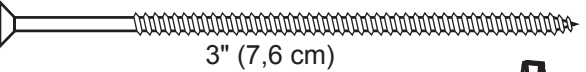
x4  3" (7,6 cm)

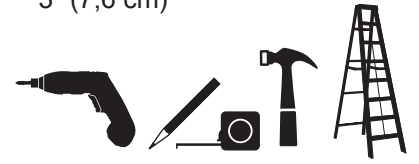

✓ BEGIN

1 Install loft support **PT** flush under wall top plates. Secure using 3" nails into wall studs.

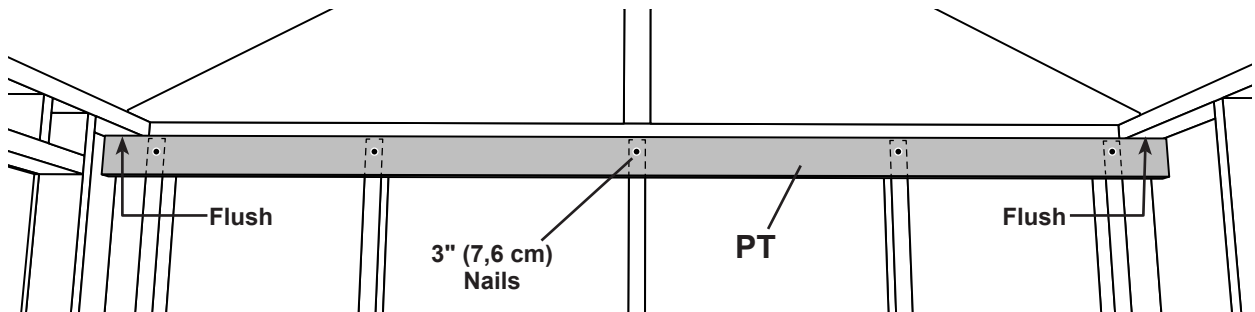

2 Place **TP** on upper window frame flush against back side of window spacer **PU** (Fig. A) and back side of wall stud (Fig. B).

Secure **TP** using (4) 3" screws (Fig. A, B).

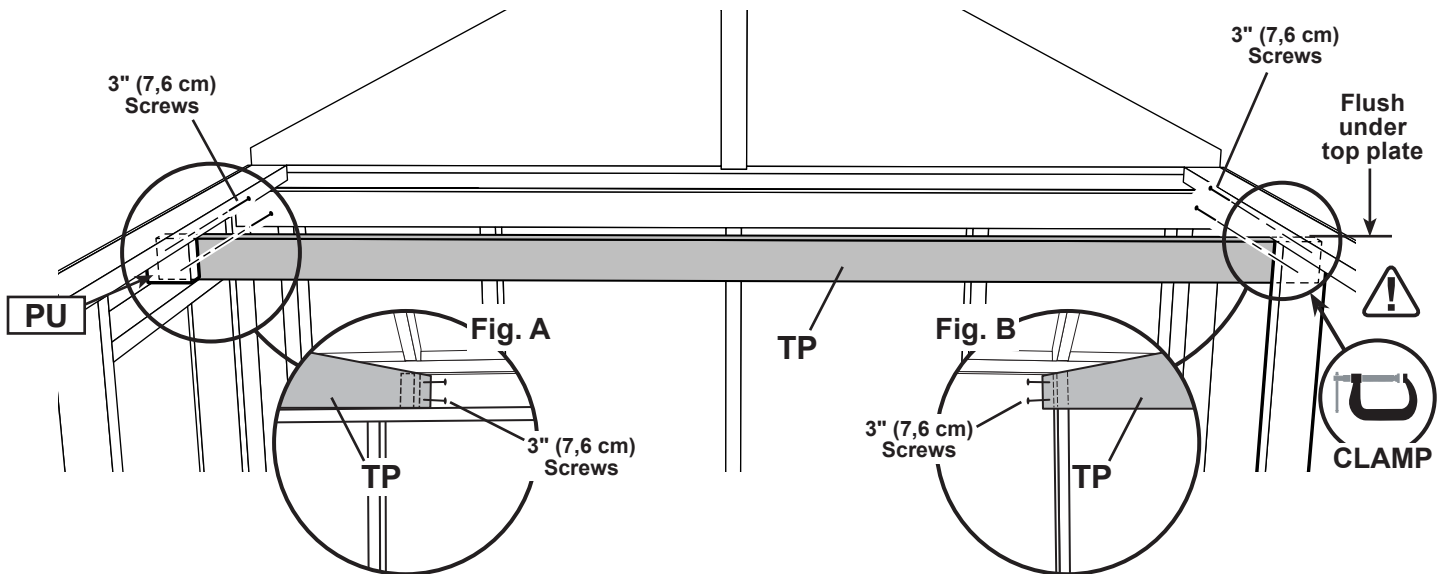

LOFT

PARTS REQUIRED:

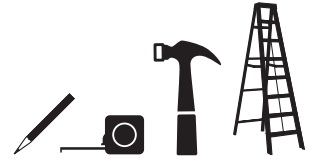
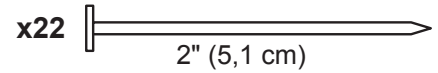
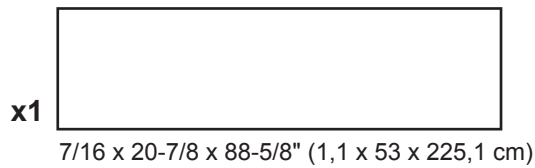

3 Place loft panel on loft frame.

Secure panel to loft frame using 2" nails spaced evenly as shown.

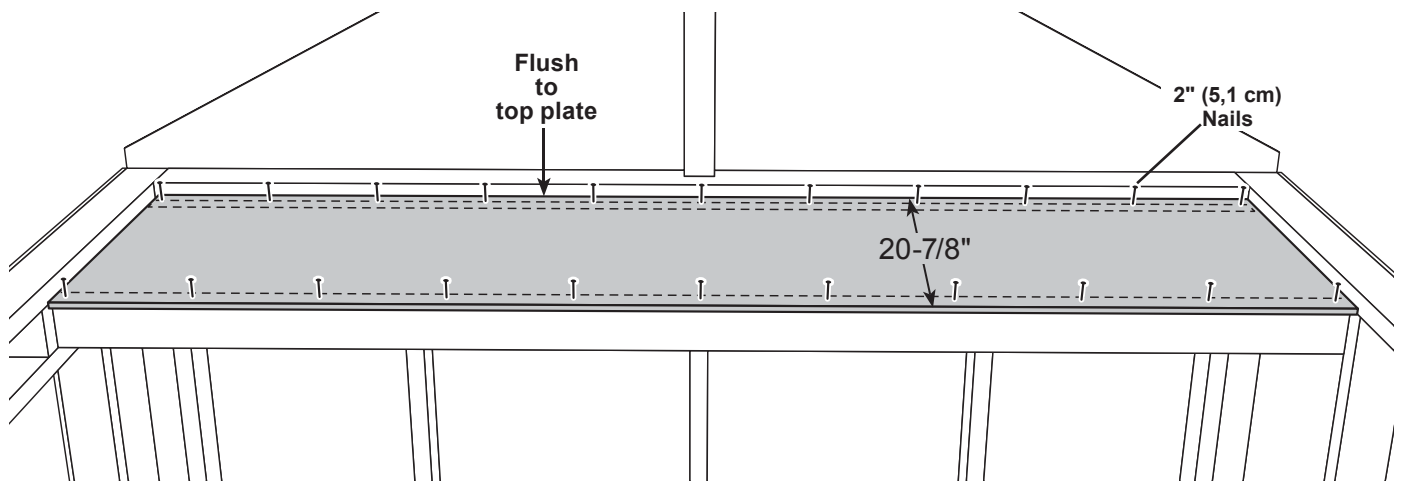

Attention:
Load not to exceed
250 lbs (113,4 kg) evenly
distributed across loft.



You have finished installing your loft.

RAFTERS

PARTS REQUIRED:

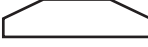
x10  6 x 23-1/4" (15,2 x 59,1 cm)

x10  AA 2 x 4 x 55-3/16" (5,1 x 10,2 x 140,2 cm)

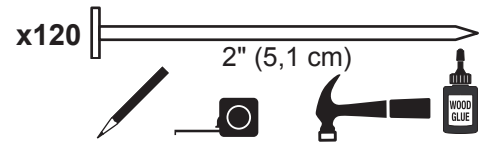

✓ **BEGIN**

You will build FIVE rafter assemblies.

- 1 Place two rafter-halves into corners on bottom plates flush to side wall studs as shown. Set rafter ends flush to front and back wall panels.

 **Rafters should touch at peak.** Apply glue on gusset and place on rafters.

Nail gusset to rafter using 2" nails, staggered, as shown. Maintain 1/4" gap (**Fig. A**).

- 2 Turn rafter assembly over. Glue and nail second gusset to back side.

 **HINT:**
Use floor and walls to help assemble rafters!

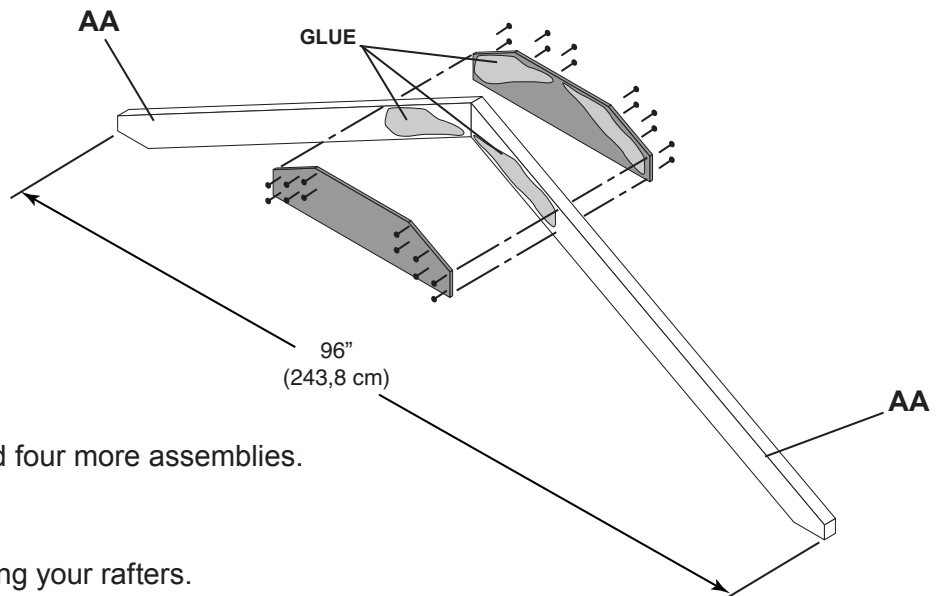
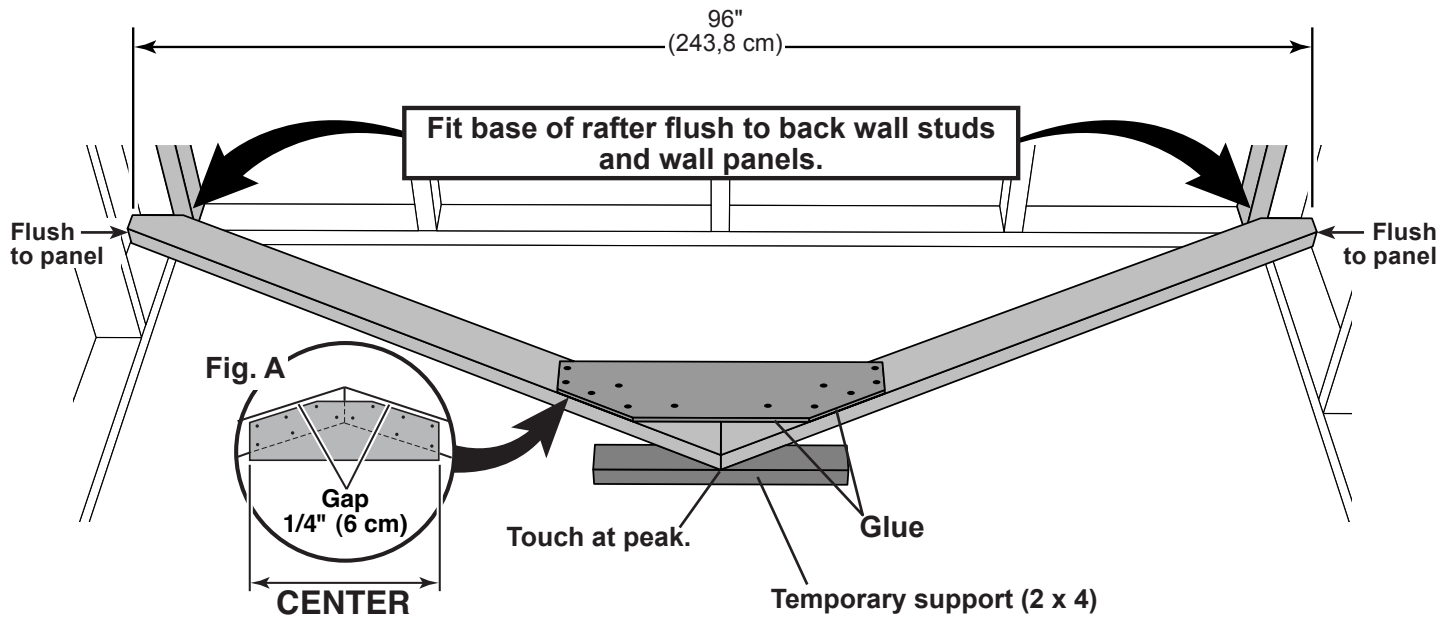

- 3 Repeat STEPS 1 - 2 to build four more assemblies.

 **FINISH**

You have finished assembling your rafters.

RAFTER INSTALLATION

PARTS REQUIRED:

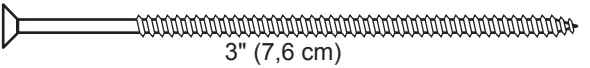
x20  3" (7,6 cm)



✓ **BEGIN**

- 1** Mark top plate to measurements shown.
Locate rafters centered on marks as shown. 

HINT: *Secure the rafters to the front side of shed first, then secure the back.*

- 2** Secure all rafters in position using two 3" (7,6 cm) screws at each connection (**Fig. A**).

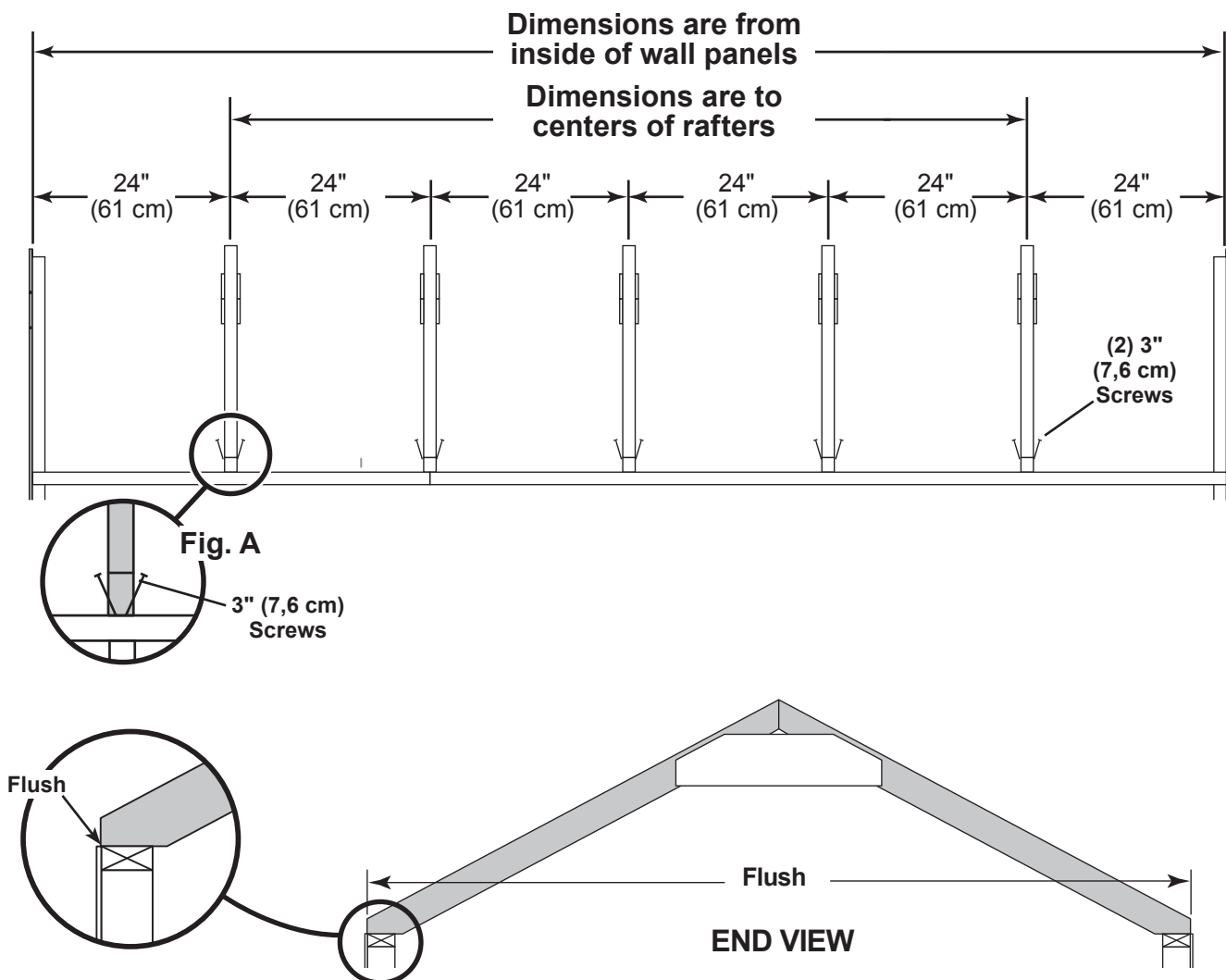

 **FINISH**

You have finished installing your rafters.

GABLE TRIM

PARTS REQUIRED:

x4 **ETA**
2 x 3 x 59-1/8" (5 x 7,6 x 150,2 cm)



✓ **BEGIN**

- 1 Place all **ETA** parts flush with tops of rafters and centered at peak (**Fig. A, Fig. B**). Attach trim with 1-1/4" screws from inside (**Fig. C**).

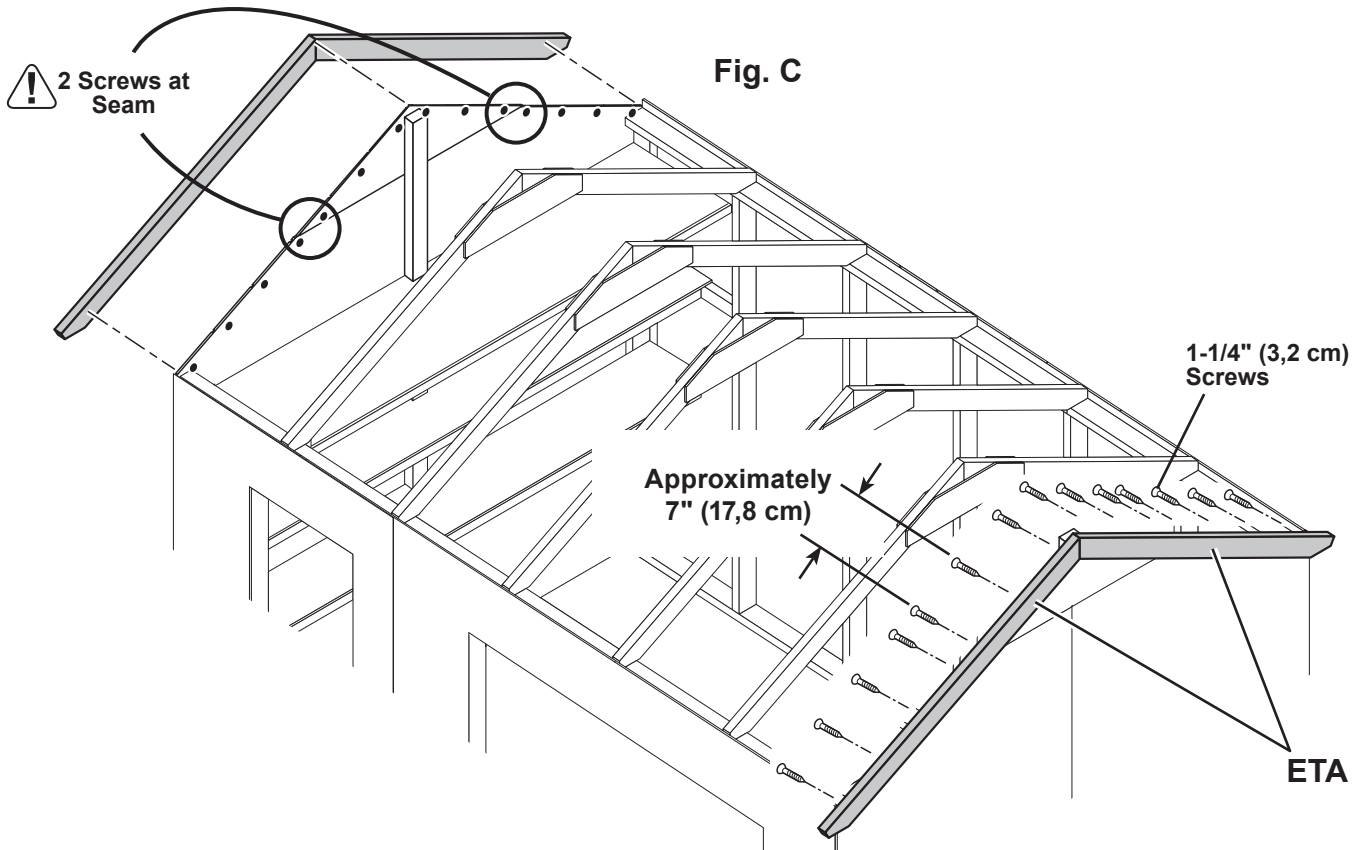
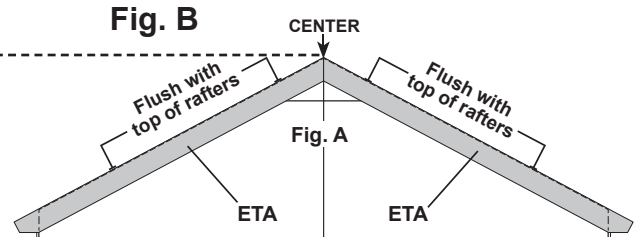
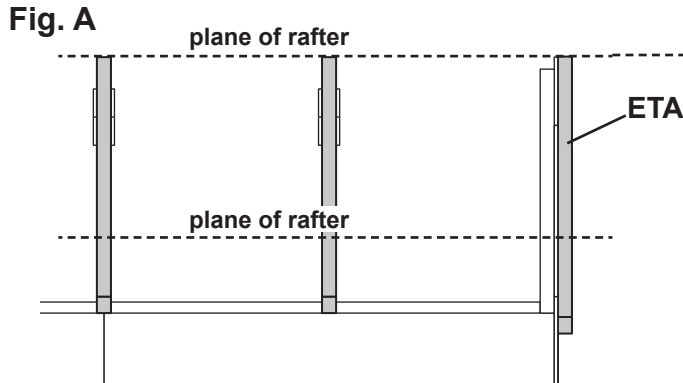



You have installed your gable trim.

ROOF PANELS

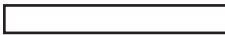
PARTS REQUIRED:

x2 
 7/16 x 11 x 96"
 (1,1 x 27,9 x 243,8 cm)

x4 
 7/16 x 11 x 25-58"
 (1,1 x 27,9 x 65,1 cm)

x2 
 7/16 x 48 x 96"
 (1,1 x 121,9 x 243,8 cm)

x4 
 7/16 x 25-5/8 x 48"
 (1,1 x 65,1 x 121,9 cm)

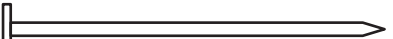
x4 
 2" (5,1 cm)

**3/4" GAUGE
 BLOCK**

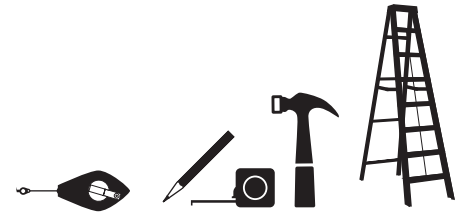

Roof panels may cause serious injury until securely fastened.

Note: all roof panels need to be installed with the rough side up (painted grid lines).

✓ **BEGIN**



- 1 Attach the **48" x 96"** panel with a **3/4"** measurement on the rafter (**Fig A**) and the panel flush at the peak (**Fig. B**).

Secure panel with two 2" nails in the corners.

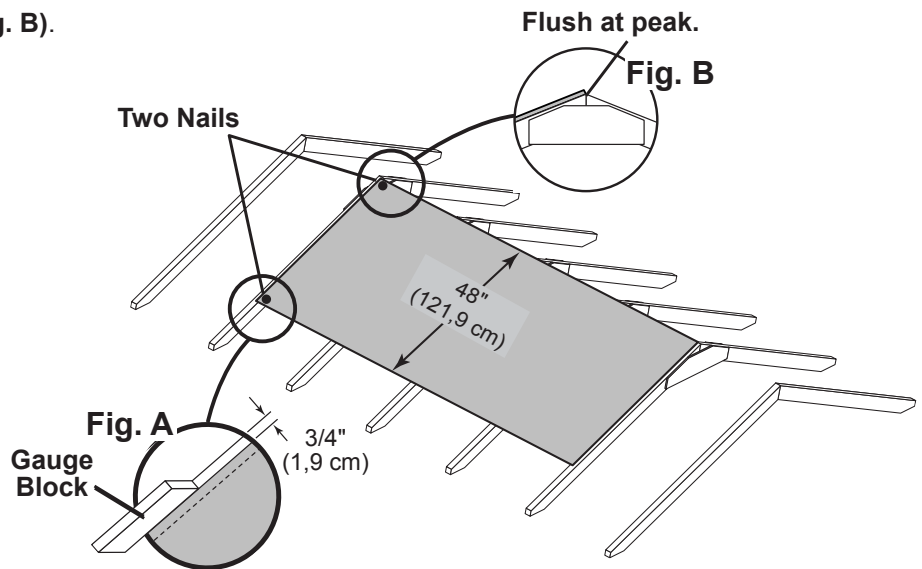

- 2 Move to the opposite end. Using the long edge of the panel as a lever, move the panel side-to-side until the top corner is flush to the peak (**Fig. C**) and there is **3/4"** measurement on the rafter (**Fig. D**).

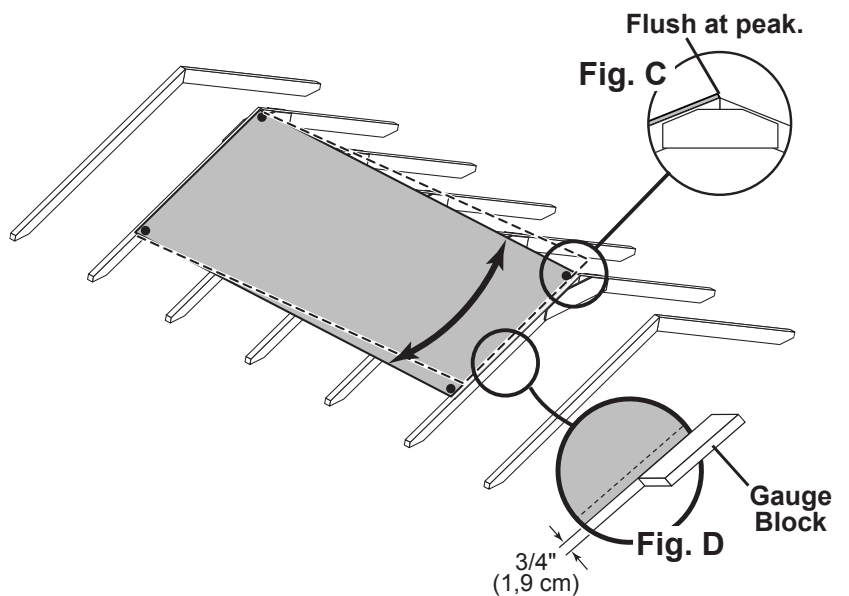

ROOF PANELS

PARTS REQUIRED:

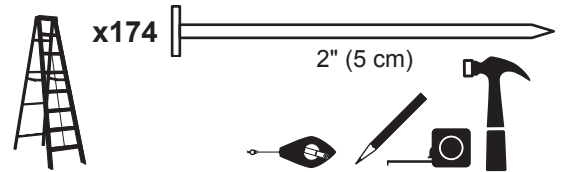

- 3** Nail the roof panel using 2" (7,6 cm) nails 6" apart on edges and 12" apart inside panel.

Attach a 11" x 96" lower roof panel flush to first panel along edge and with the 3/4" measurement on edges (Fig. F).

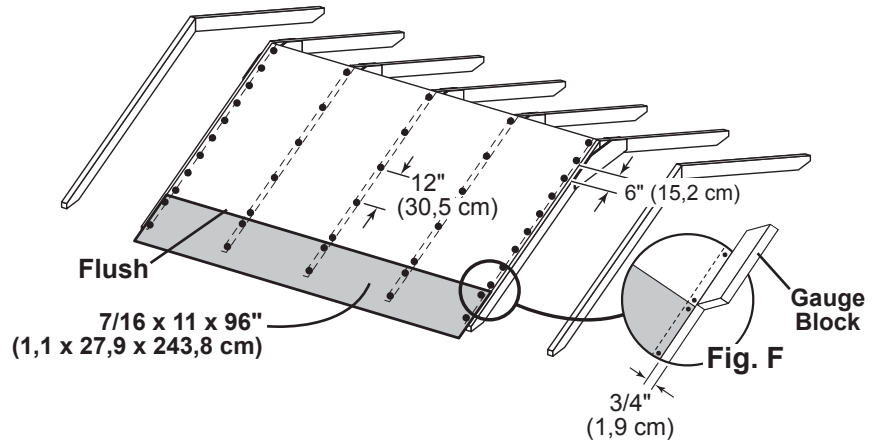

- 4** Attach the four remaining end roof panels with 2" nails 6" apart as shown (Fig. H, Fig. J).

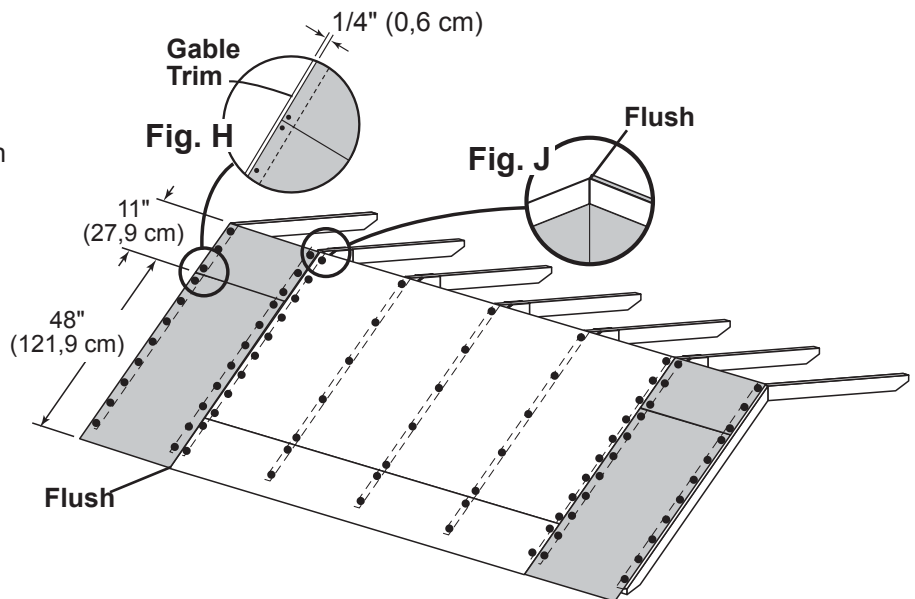

- 5** Repeat process to attach roof panels on the opposite side.



Your roof panels are now installed.

COLLAR TIES

PARTS REQUIRED:

x2 **GUA**
1 x 3 x 60" (2,5 x 7,6 x 152,4 cm)

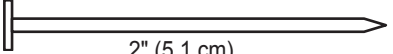
x12  2" (5,1 cm)

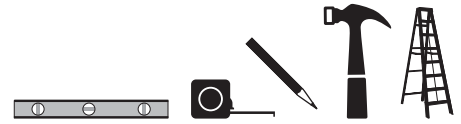

✓ **BEGIN**

1 Place and level collar ties **GUA** on **2nd rafter** (which is the rafter above center of the door) and on back of **4th rafter**.



Ensure collar tie is level and flush to roof panels.

Secure collar tie to rafter using three 2" nails at each end.

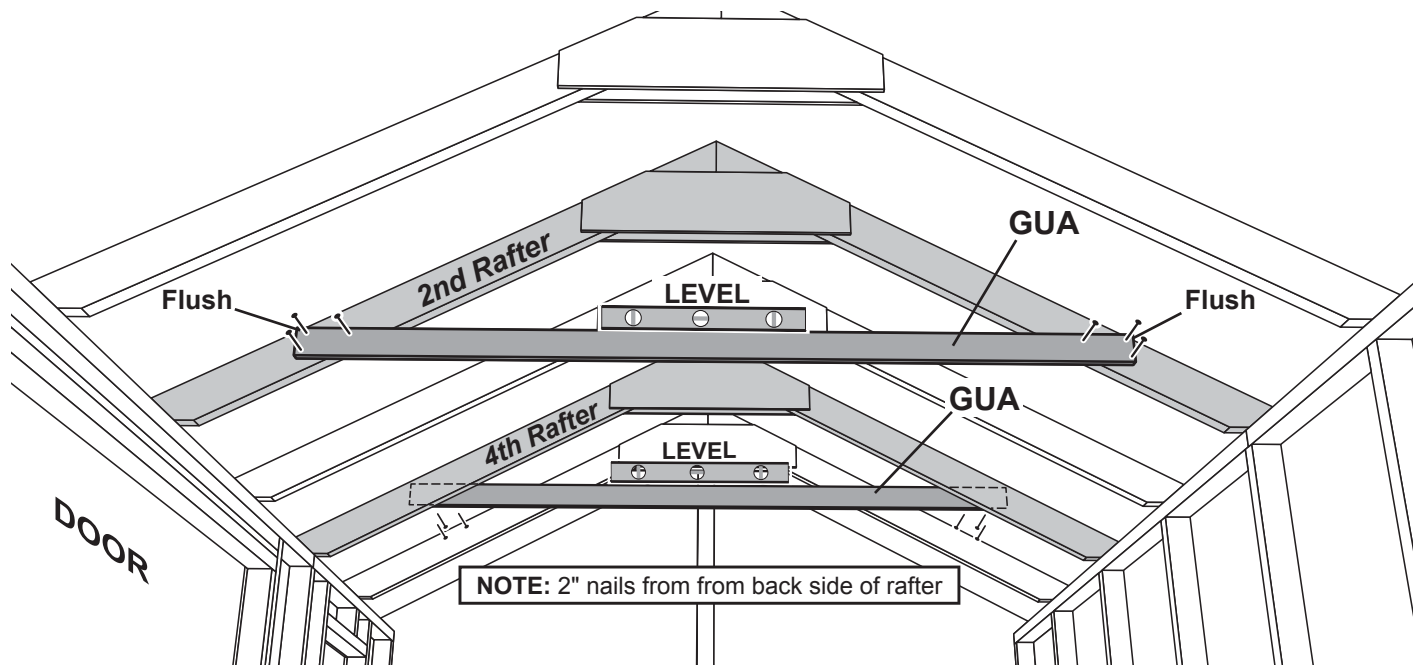

You have finished installing your collar ties.

SOFFIT TRIM

PARTS REQUIRED:

x2 **AN**
2 x 4 x 48-3/4" (5,1 x 10,2 x 123,8 cm)

x2 **TP**
2 x 4 x 96" (5,1 x 10,2 x 243,8 cm)

x44  1-1/4" (3,2 cm)

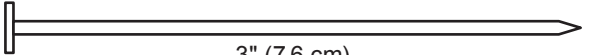
x8  3" (7,6 cm)



✓ **BEGIN**

- 1 Place parts **TP** and **AN** flush to bottom of roof overhang as shown (**Fig. A**).
Secure with 3" nails and 1-1/4" screws as shown.

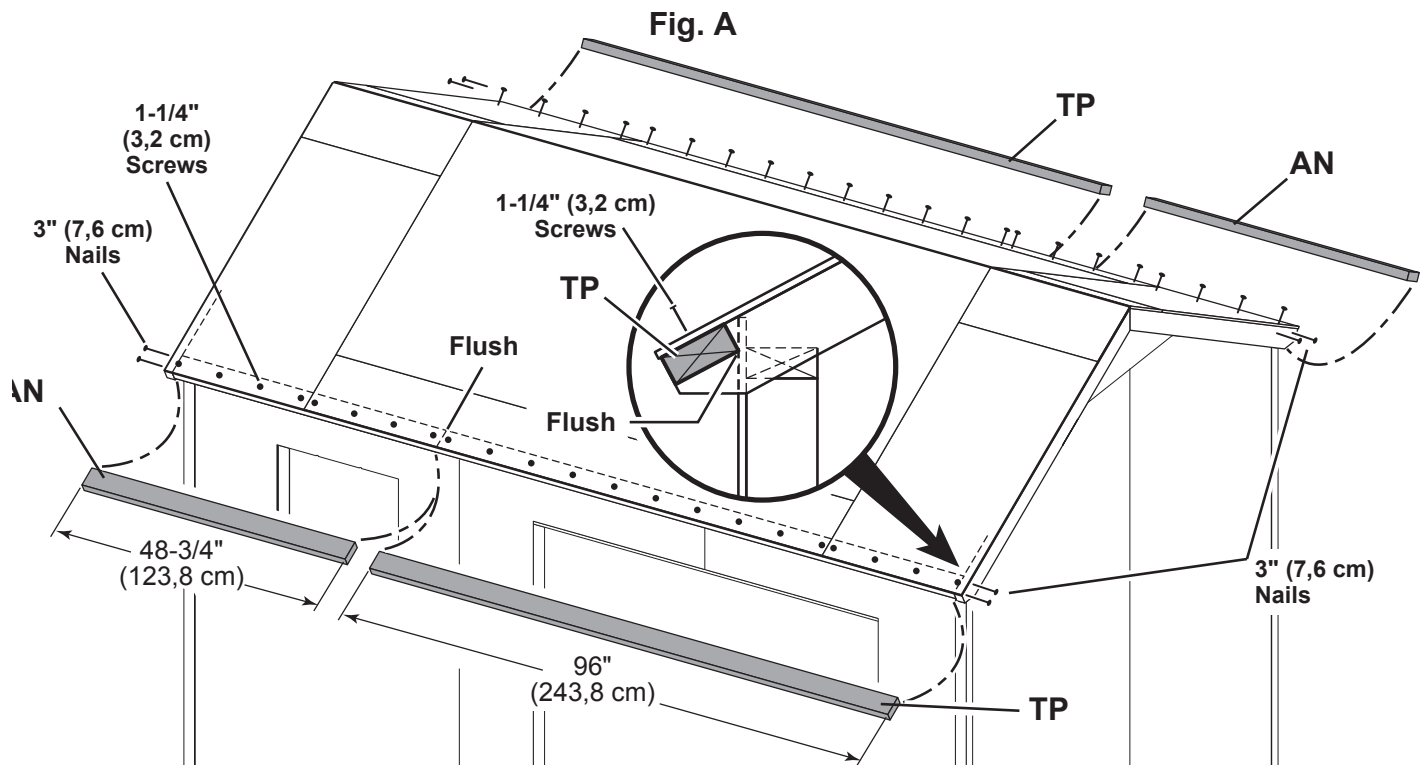

You have finished installing your soffit trim.

GABLE FILLER

PARTS REQUIRED:

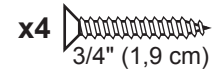
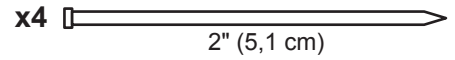
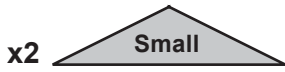

✓ **BEGIN**

- 1** Place gable fillers flush to bottom of gable trim as shown (Fig. A).
Secure with two 2" finish nails and two 3/4" screws (Fig. B).

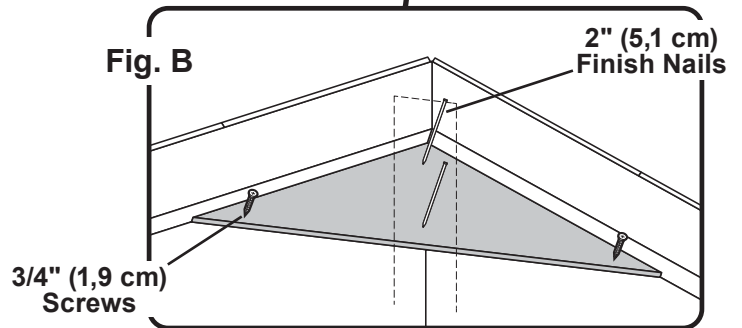
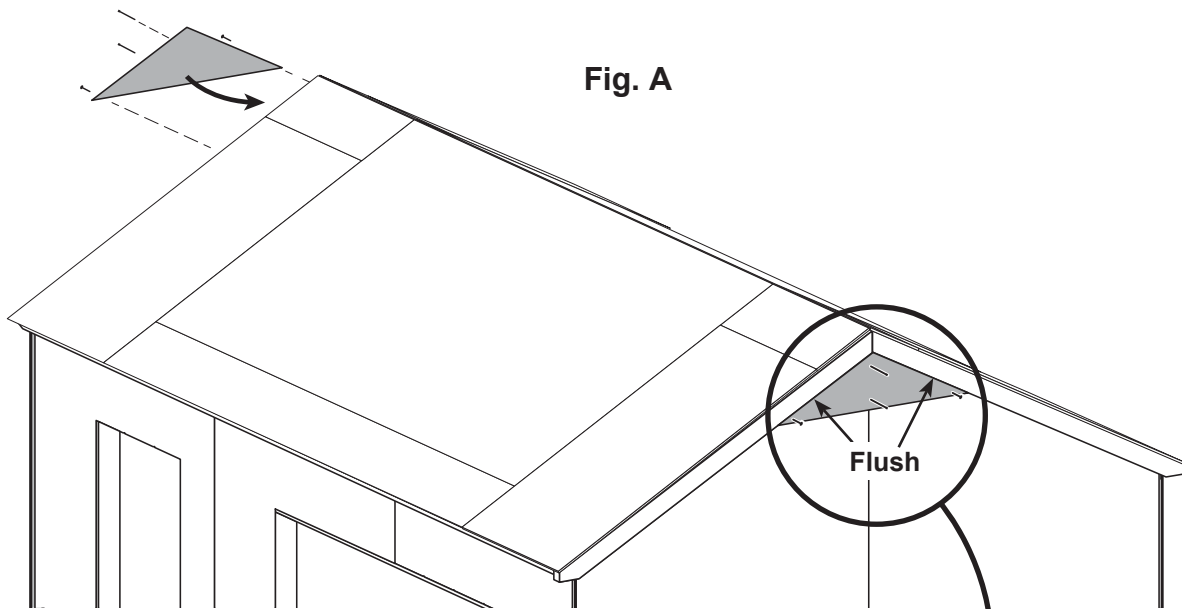

Your gable fillers are now installed.

GABLE TRIM

PARTS REQUIRED:

x2 **GFL**
19/32 x 3-1/2 x 60" (1,5 x 8,9 x 152,4 cm)

x2 **GFR**
19/32 x 3-1/2 x 60" (1,5 x 8,9 x 152,4 cm)

x40  2" (5,1 cm)



✓ **BEGIN**

- 1 Install **GFL** and **GFR** primed side out, flush to top of roof panels and flush at peak. Secure to 2x3 trim using 2" finish nails spaced evenly in the pattern shown.

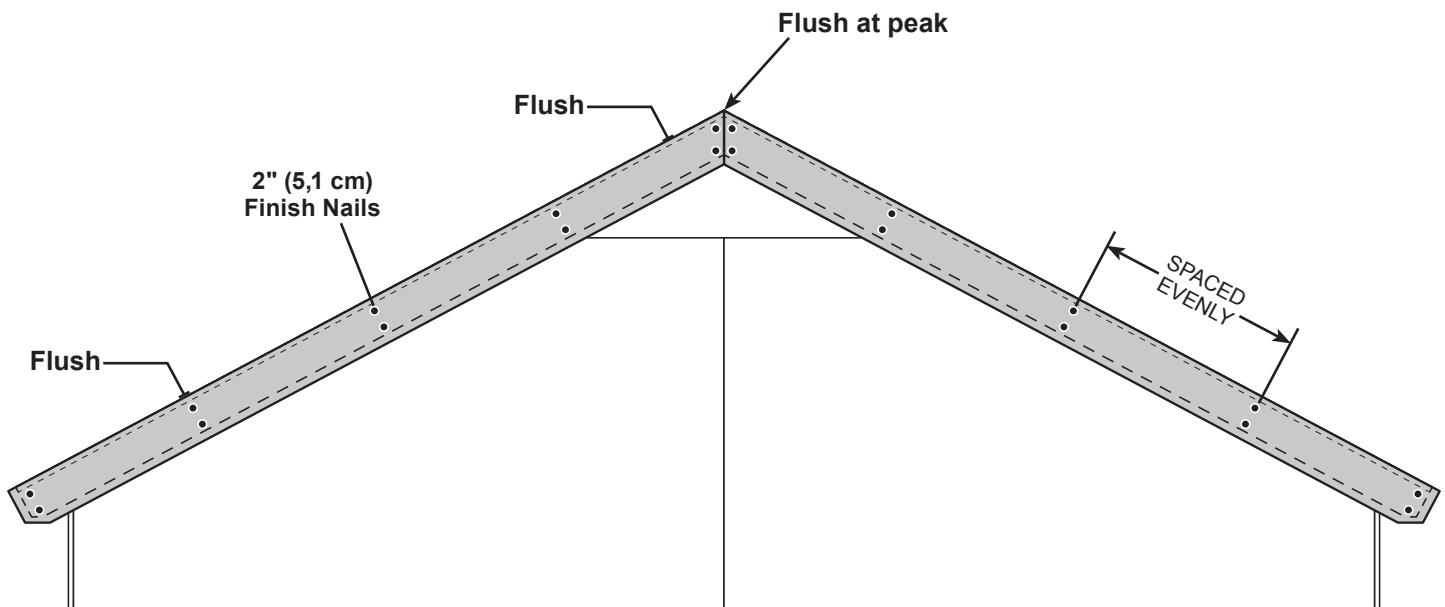

- 2 Repeat STEP 1 to install **GFL** and **GFR** on opposite side.



Your gable trim is now installed.

EAVE FASCIA

PARTS REQUIRED:

x4 
3/8 x 2-1/2 x 73-7/8" (1 x 6,3 x 187,6 cm)

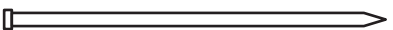
x32 
2" (5,1 cm)



✓ **BEGIN**

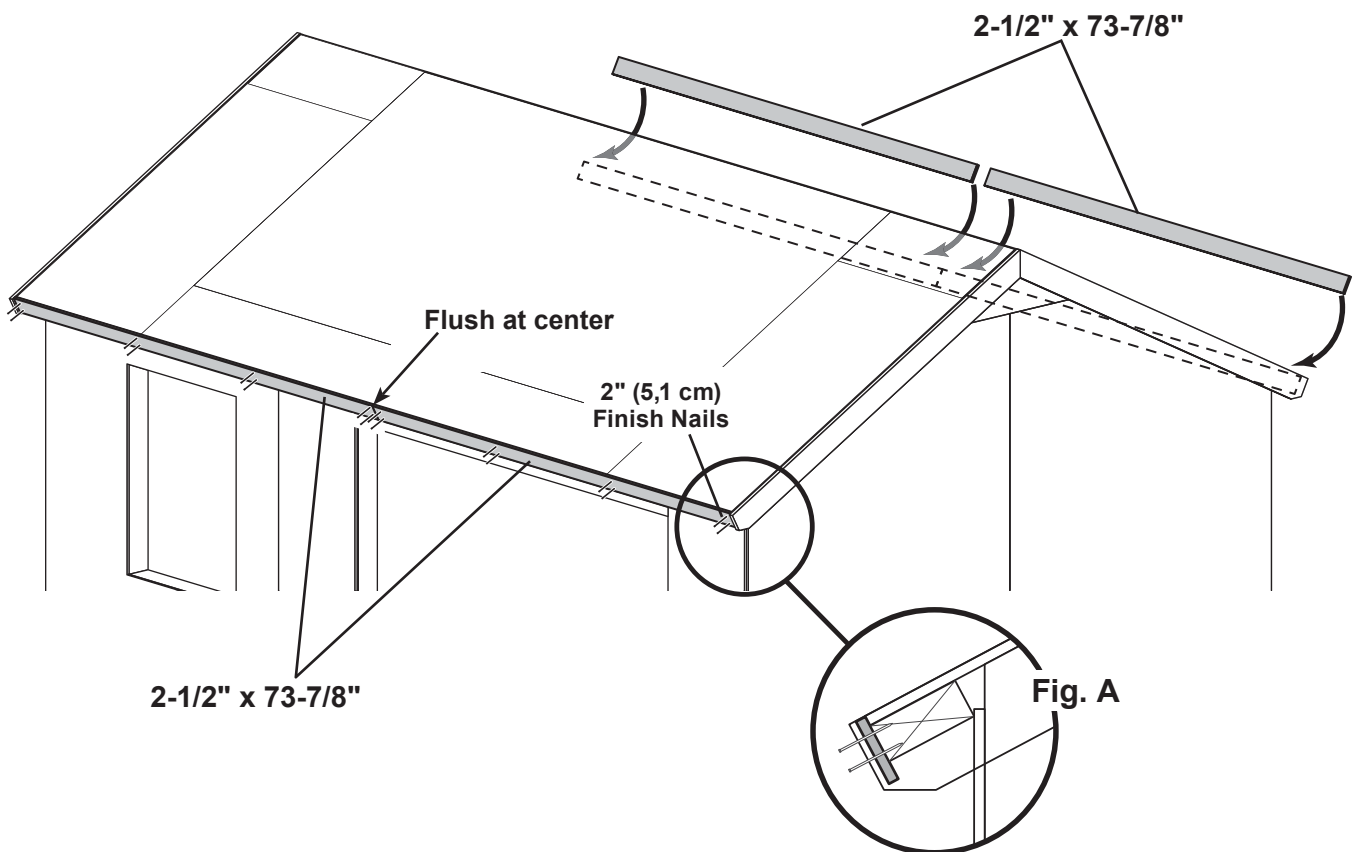

- 1** Install fascia 2-1/2" x 73-7/8" flush to top of roof roof panel as shown (Fig. A).
Secure to soffit 2x4 trim using 2" finish nails.



Your eave fascia is now installed.

CORNER TRIM

PARTS REQUIRED:

- x4  3/8 x 1-3/4 x 75-3/4" (1 x 4,4 x 192,4 cm)
- x2  3/8 x 1-3/4 x 75-7/16" (1 x 4,4 x 191,6 cm) **x2 Right**
- x2  3/8 x 1-3/4 x 75-7/16" (1 x 4,4 x 191,6 cm) **x2 Left**

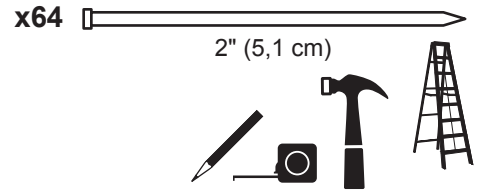

✓ BEGIN

- 1** Install **75-3/4"** front and back corner trim flush under soffit trim (**Fig. A**) and flush to side wall panels. Secure using 2" finish nails.
- 2** Install **75-7/16"** gable side corner trim flush to the bottom of the gable trim (**Fig. B**) and flush to edge of installed trim as shown (**Fig. C, Fig. D**). Secure using 2" finish nails.

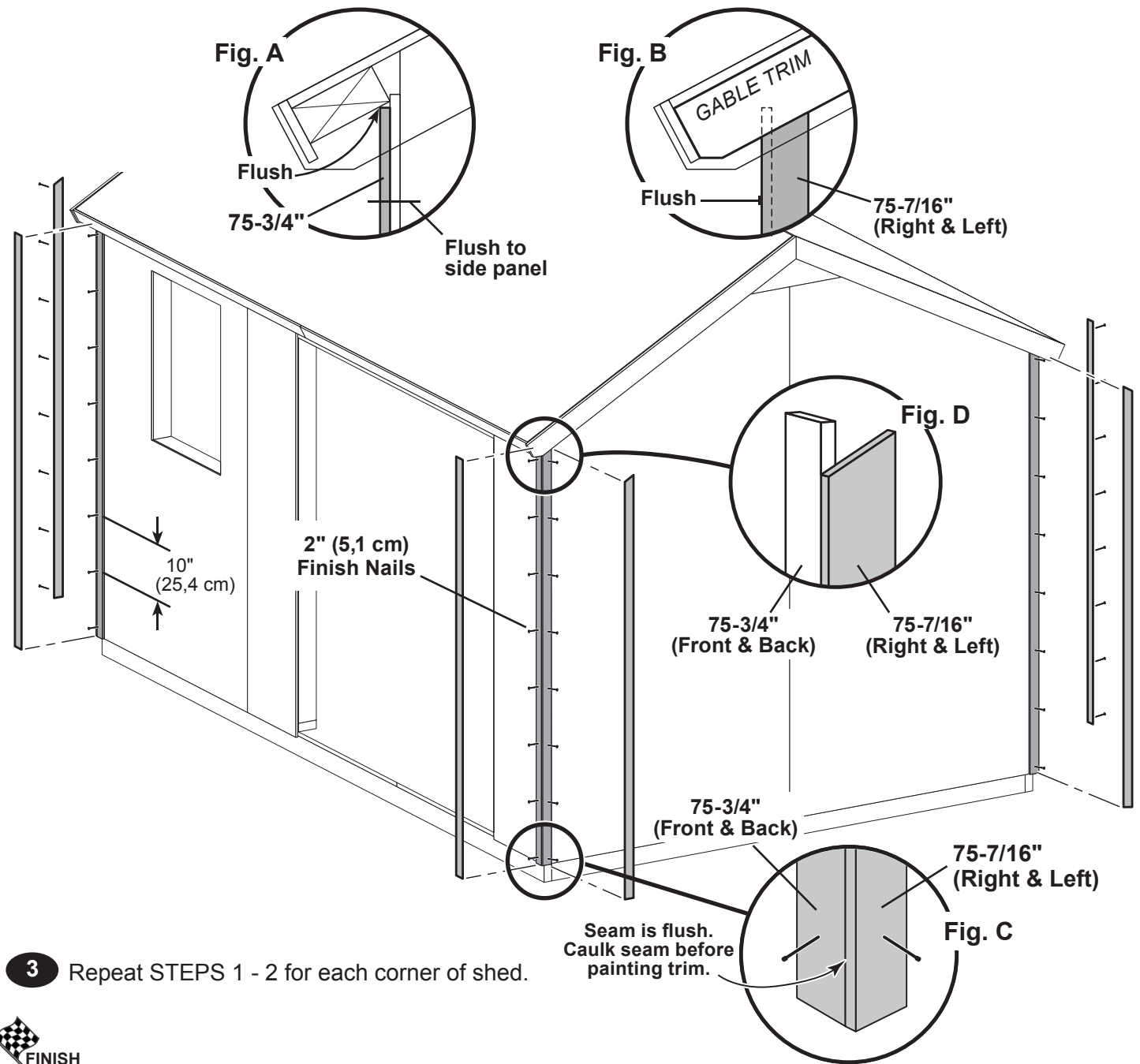

- 3** Repeat STEPS 1 - 2 for each corner of shed.



You have finished installing your corner trim.

DOORS

PARTS REQUIRED:

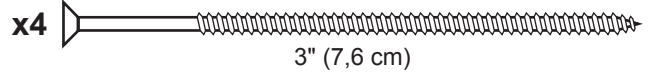
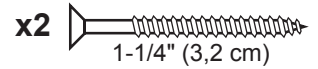
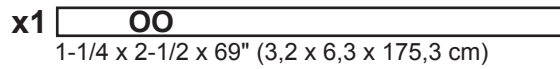
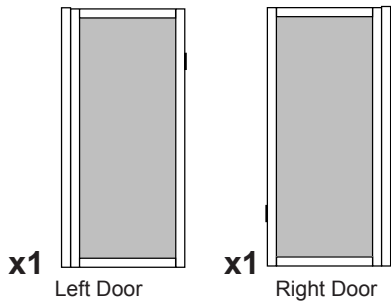

✓ **BEGIN**

- 1 Orient parts as shown on flat surface. **⚠ 3/8" offset is to top.**
Look for red (right) and green (left) on hinge board.

Attach temporary support **OO** with 3" screws.

Attach temporary support **GAA** at bottom with 1-1/4" screws.

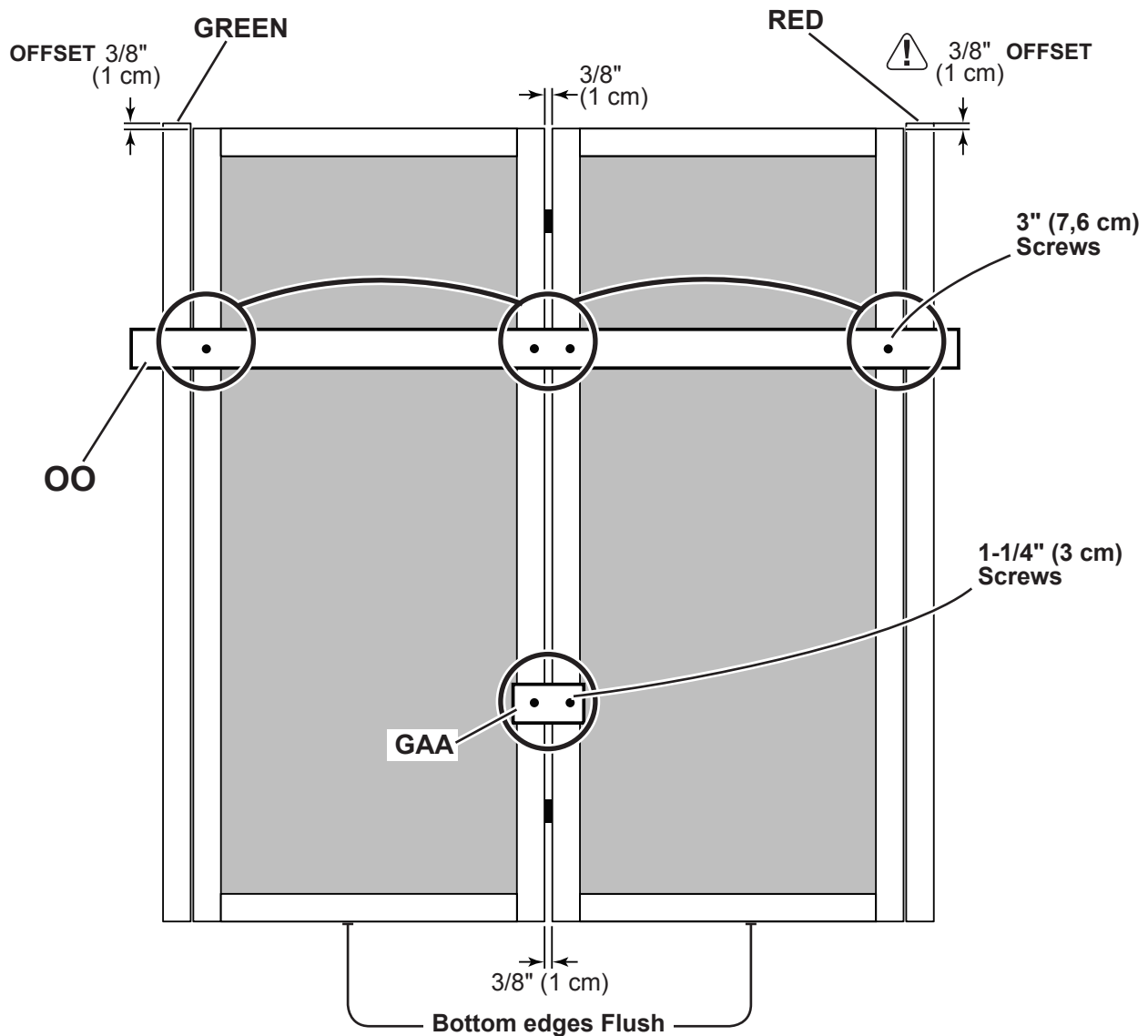

DOORS

PARTS REQUIRED:

x1 **ZO**
19/32 x 4 x 72" (1,5 x 10,2 x 182,9 cm)

x1 **OO**
1-1/4 x 2-1/2 x 69" (3,2 x 6,3 x 175,3 cm)

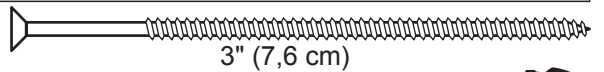
x13  3" (7,6 cm)

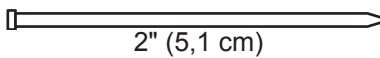
x5  2" (5,1 cm)

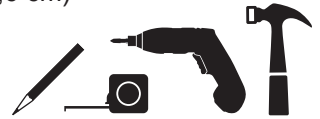

- 2 Place over-door trim **ZO** centered above door opening and flush up to the soffit (**Fig. A**). Secure using 2" finish nails. Measure and mark a center line on **ZO**.
- 3 Measure down 72" from over door trim **ZO**. Mark at 72" (**Fig. B**). Place and center **OO** as a ledger board at 72" measurement for doors to rest on. Secure **OO** using three 3" screws (**Fig. C**).

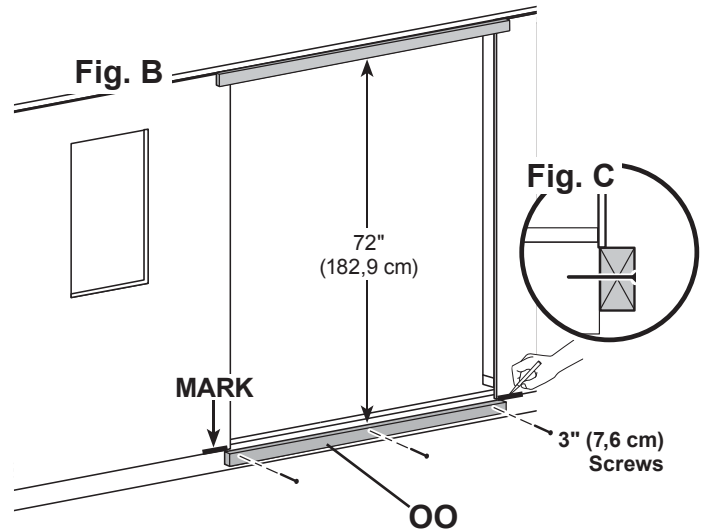
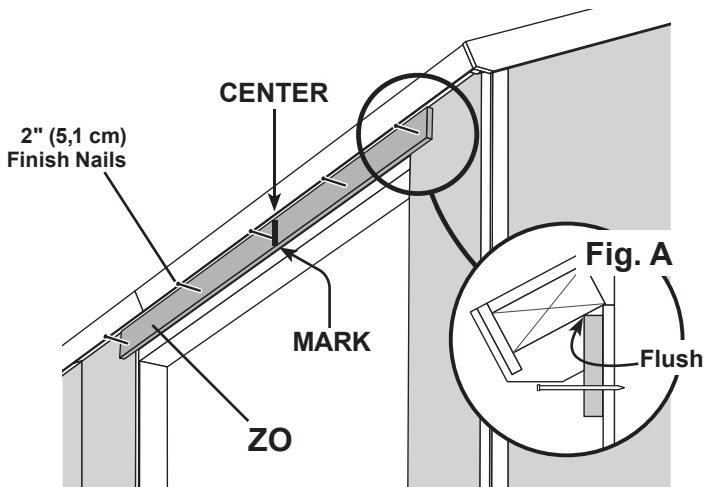

- 4 Center doors on mark as shown (**Fig. B**) and screw hinge boards into door framing using 3" screws.

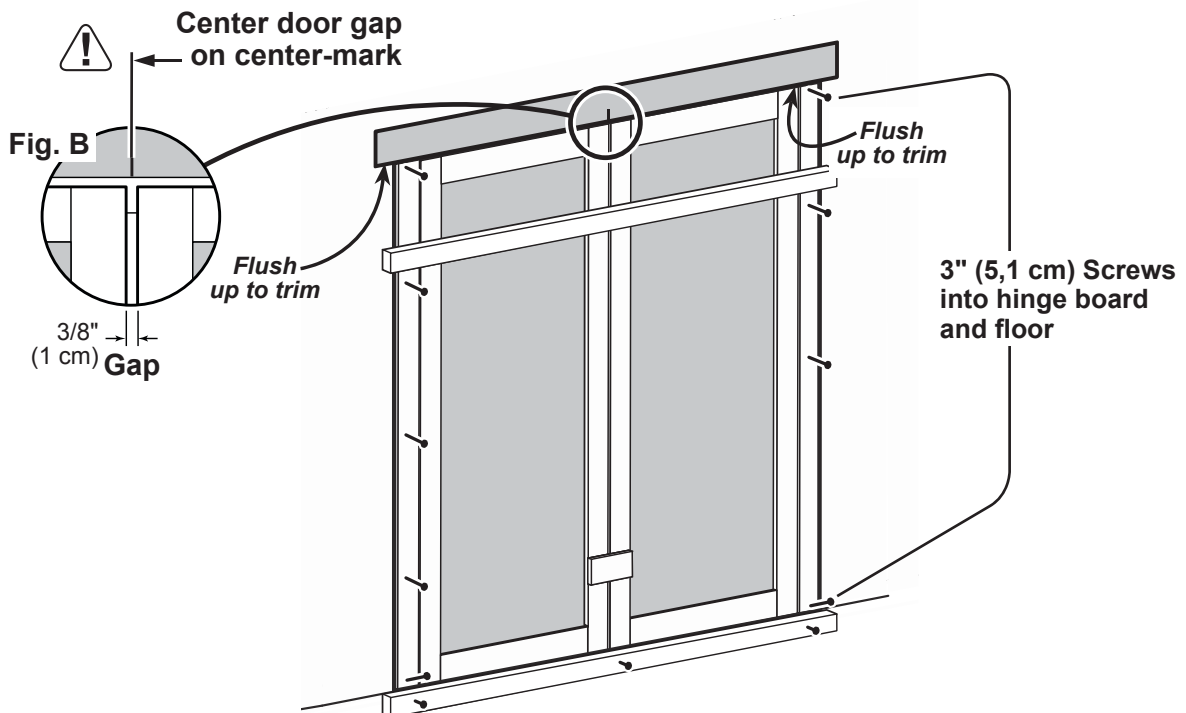

Remove temporary door supports and ensure that the doors open properly.

You have finished installing your doors.

DOOR TRIM

PARTS REQUIRED:

x4 **AH**
19/32 x 3 x 26-5/8" (1,5 x 7,6 x 67,6 cm)

x11  3/4" (1,9 cm)
Bagged separately / special coating

x1  64" Metal Threshold

x56  3/4" (1,9 cm)

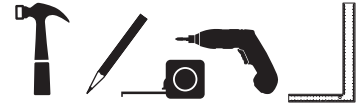

✓ BEGIN

- Secure door trim from inside using 3/4" screws as shown (Fig. A). Attach horizontal door rails **AH** with four 3/4" screws from inside of doors.
- Reinforce the door trim using 3/4" screws through door panel into trim (Fig. A). Locate screws as shown (Fig. B). Use two screws at seams.

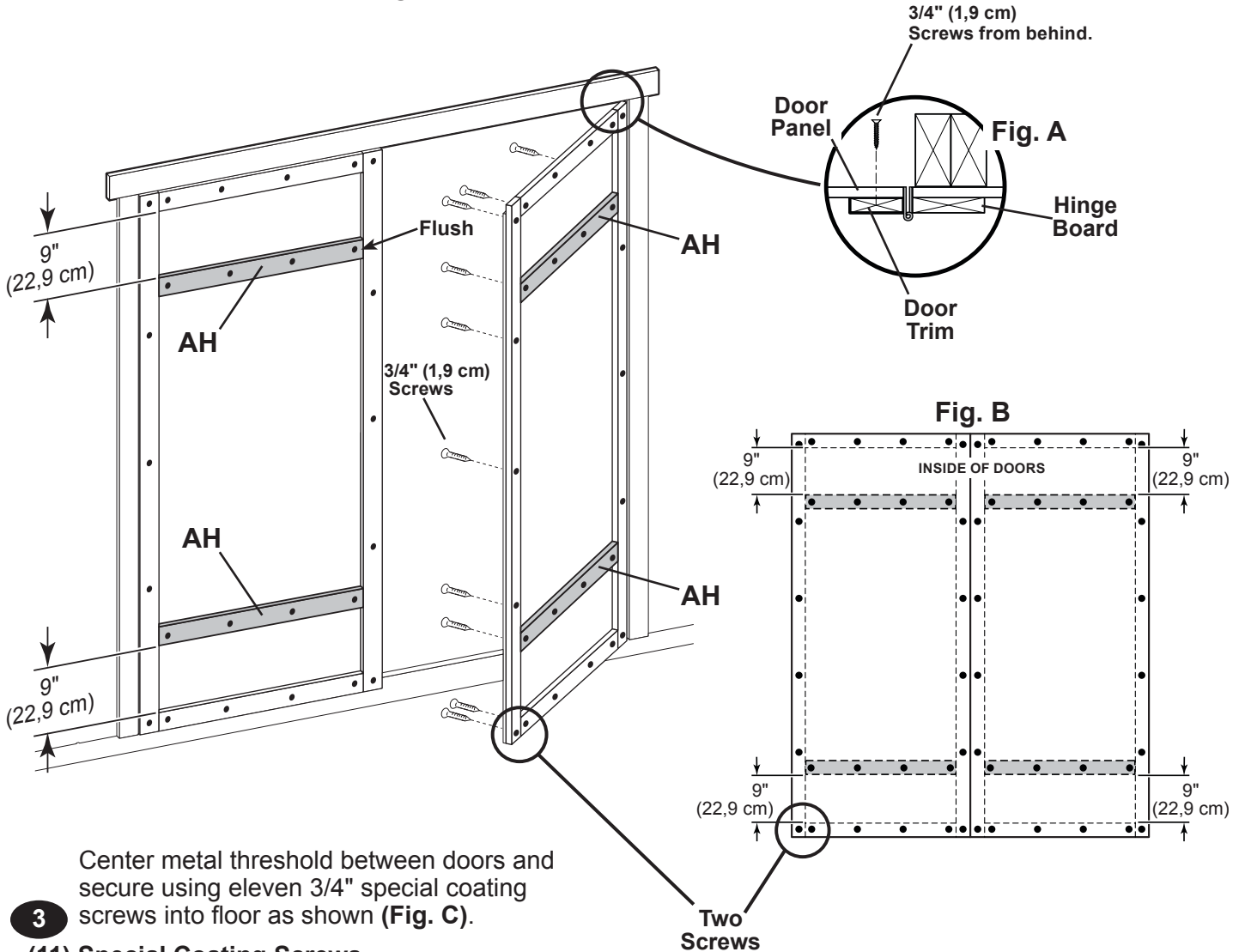

- Center metal threshold between doors and secure using eleven 3/4" special coating screws into floor as shown (Fig. C).

(11) Special Coating Screws

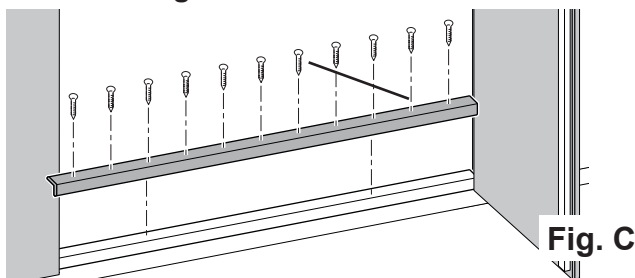

You have finished attaching your door trim and threshold.

DOOR STIFFENERS

PARTS REQUIRED:

x2 **OO**
1-1/4 x 2-1/2 x 69" (3,2 x 6,3 x 175,3 cm)

x10
2" (5,1 cm)



✓ **BEGIN**

- 1** Center **OO** vertically on the left door in the door opening flush with the edge of door (**Fig. A**).
- 2** Secure using (5) 2" screws through outside trim into **OO** (**Fig. B**)

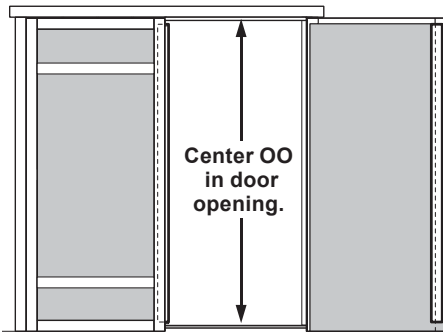
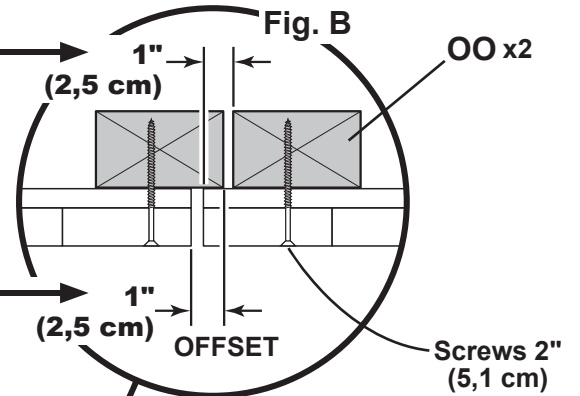
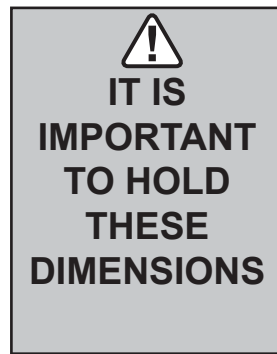
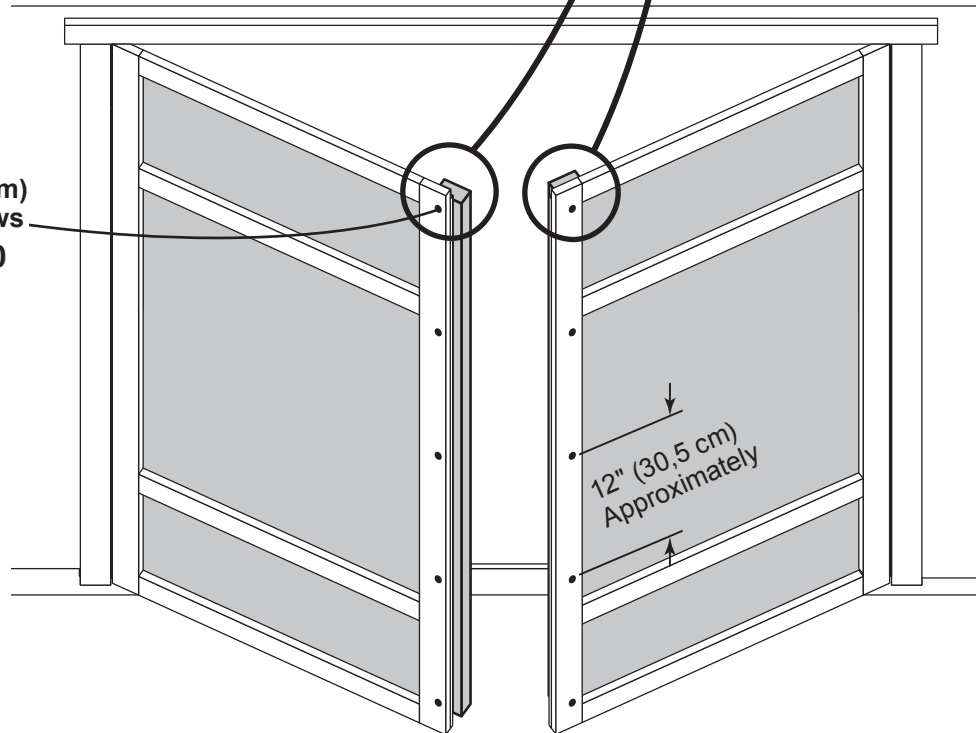

Fig. A



2"
(5,1 cm)
Screws
x10



- 3** Repeat STEPS 1 - 2 to install **OO** on right door.



FINISH
You have finished installing your door stiffeners.

DOOR HARDWARE

PARTS REQUIRED:

x1

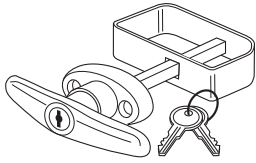

x4

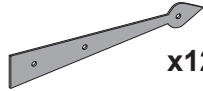

x12

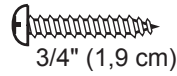

x2

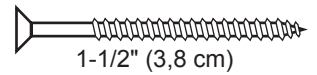

✓ BEGIN

- 1 Measure and mark position on right door as shown.
Pre-drill 1/4" hole at mark. Finish hole with 1/2" drill bit.
- 2 Position hardware in hole and secure with screws as shown.
- 3 Install decorative hinges on horizontal trim and flush against hinge as shown.

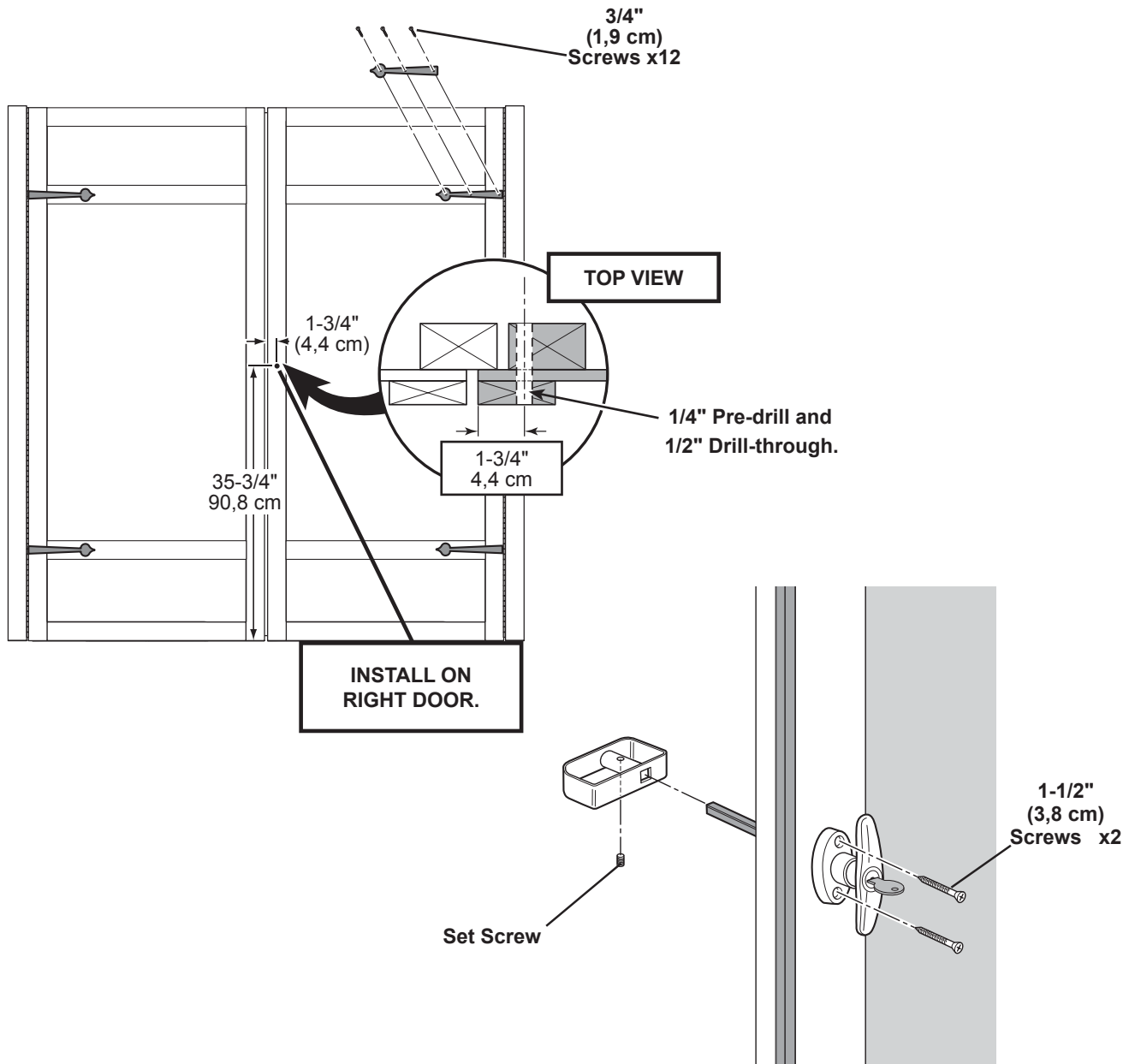

You have finished mounting your door hardware.

DOOR HARDWARE

PARTS REQUIRED:

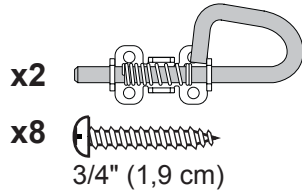

5/16" (0,8 cm) Drill Bit



✓ BEGIN

- 1 Place bolt onto **OO** in open position with bolt end 3/8" (0,8 cm) down from frame. Bolt is open when loop is contacting base (**Fig A**).
- 2 Mark and pre-drill holes for screws. Install bolt with screws supplied.
Drill 5/16" (0,8 cm) hole deep enough for bolt to slide into.
- 3 Place bolt onto **OO** in open position with bolt end 1/2" (1,3 cm) up from floor. Bolt is open when loop is connecting base (**Fig. B**).
- 4 Mark and pre-drill holes for screws. Install bolt with screws supplied.
Drill 5/16" (0,8 cm) hole deep enough for bolt to slide into.



FINISH

You have finished mounting your spring bolts.

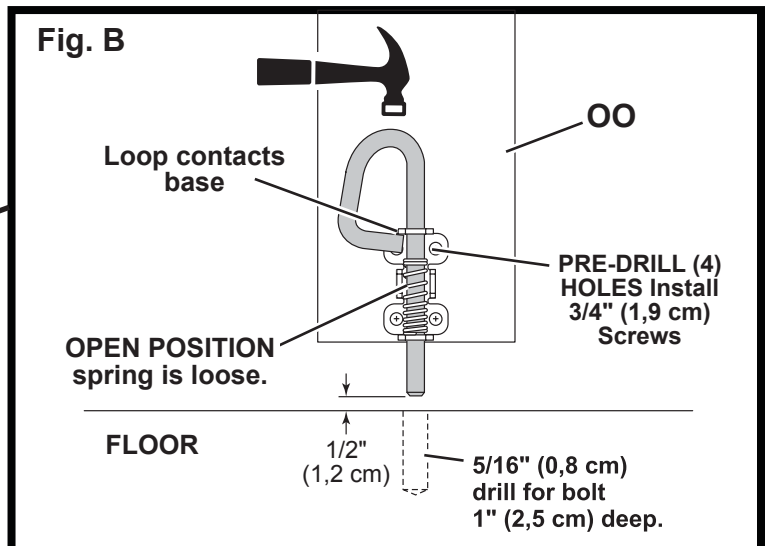
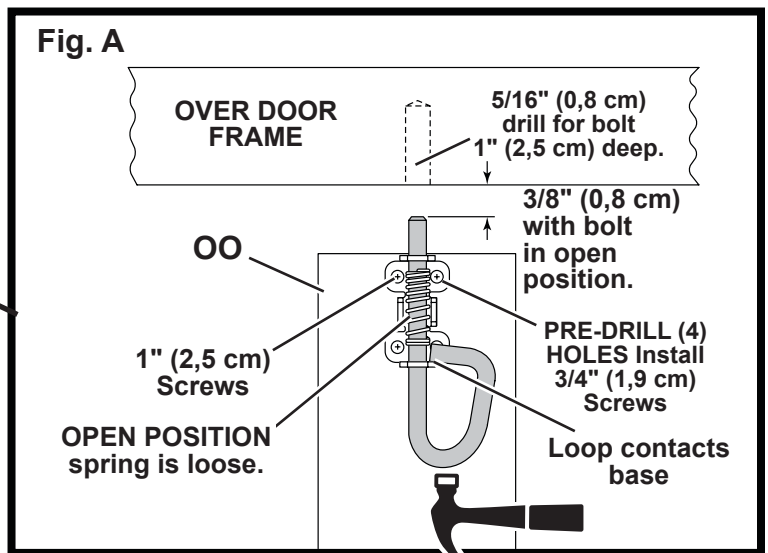
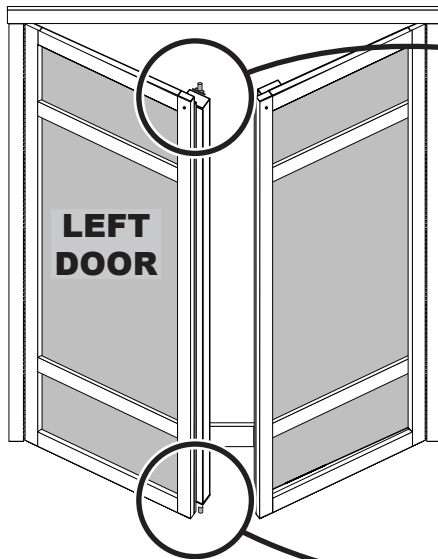

HINT: With door closed extend bolt and tap with hammer to leave a mark in wood for drilling.

WINDOWS AND WINDOW TRIM

PARTS REQUIRED:

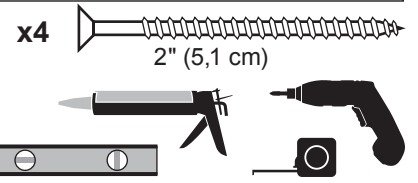
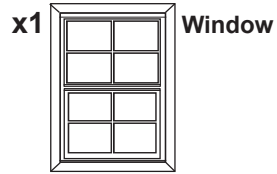

✓ BEGIN

- 1 Seal window with high-quality exterior-grade caulk before installing (**Fig. A**).
- 2 Attach window using four 2" (5,1 cm) screws as shown. Ensure window is level and centered.

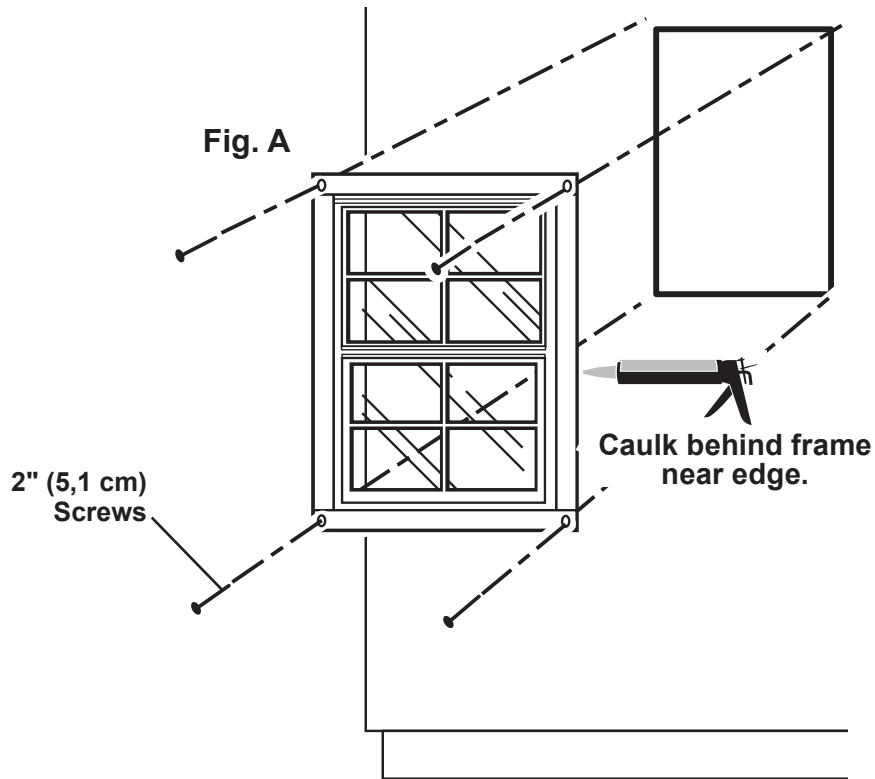

WINDOW TRIM and SHUTTERS

PARTS REQUIRED:

x2 **AZ**
19/32 x 2-1/2 x 30-1/8"
(1,5 x 6,3 x 76,5 cm)

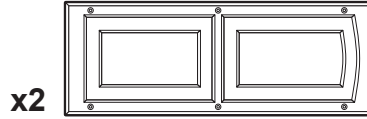

x8 2" (5 cm)



- 3** Place trim pieces **AZ** centered on window frame as shown.
Secure using 2" finish nails.

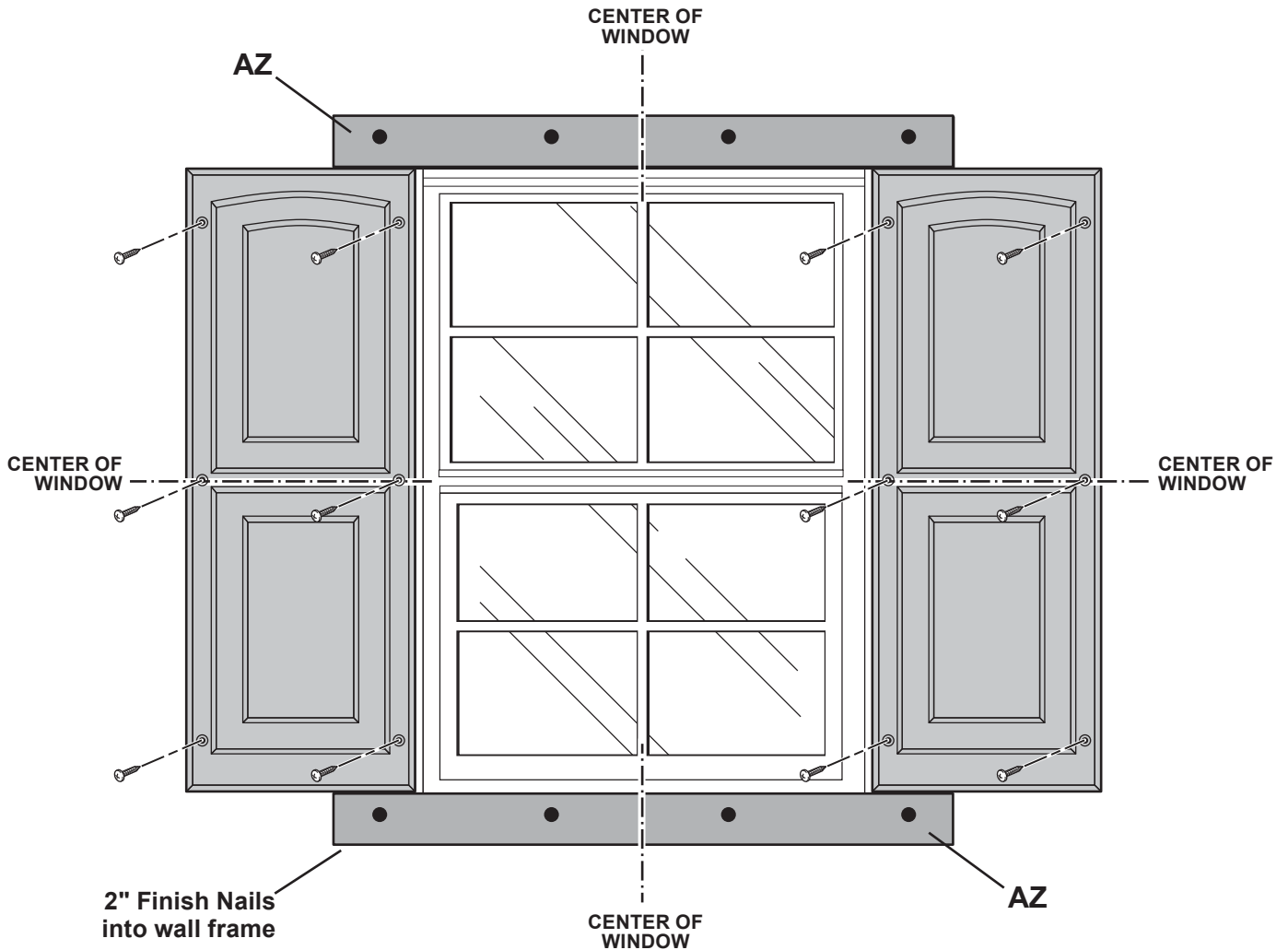

- 4** Center shutters vertically against trim.
Secure using screws provided at pre-marked locator points.
DO NOT OVERTIGHTEN!



You have finished installing your windows, window trim and shutters.

VENTS

PARTS REQUIRED:

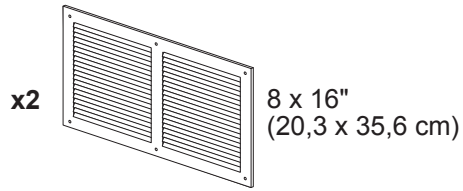

x12 
1/2" (1,3 cm)



✓ BEGIN

- 1 Choose two walls for vent locations (One low and One high). Measure and mark for two vents in walls as shown. Cut out marked openings.

Caulk behind vent flanges.

- 2 Secure using 1/2" (1,3 cm) screws.

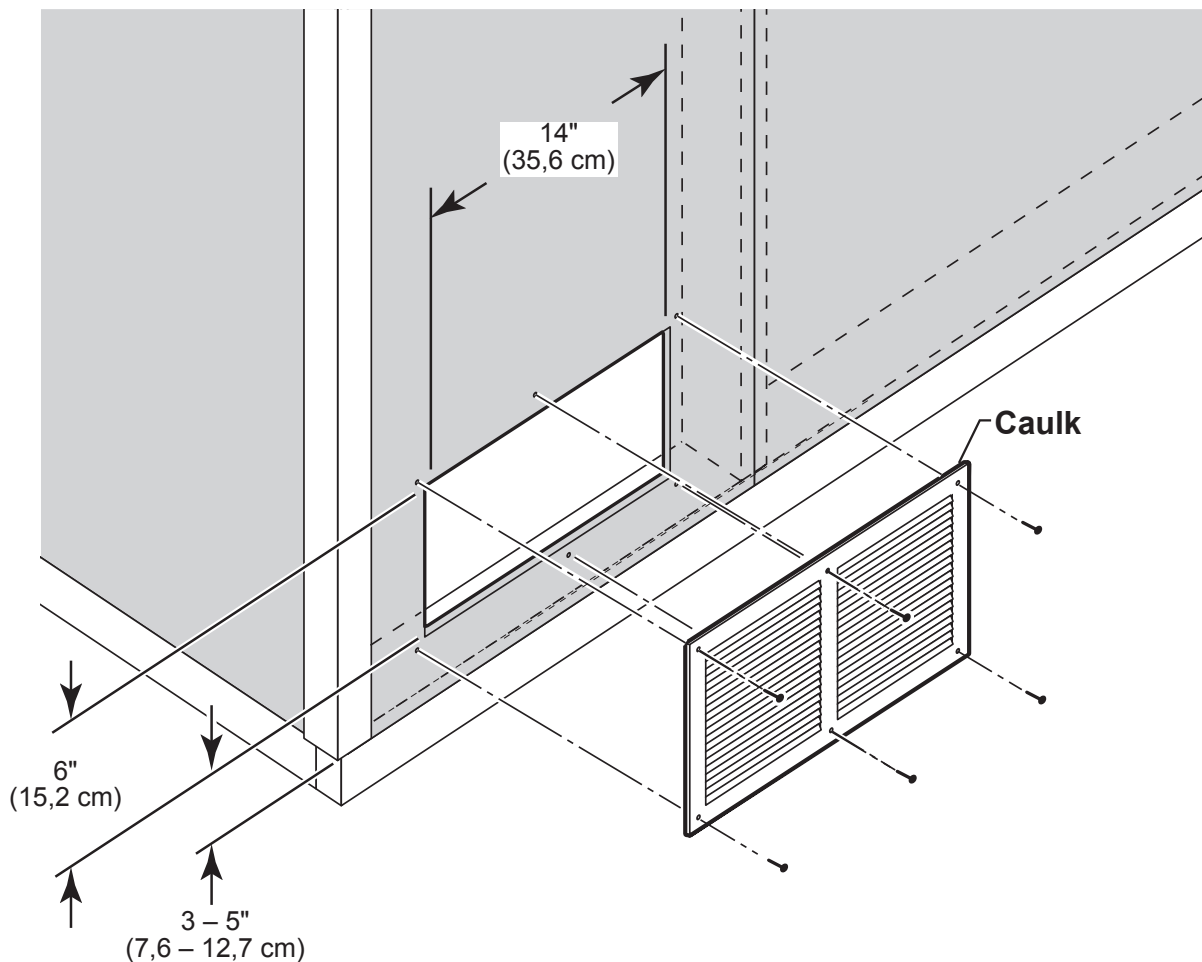

You have finished installing your vents.

PAINT & CAULK

- NOT INCLUDED -

PARTS REQUIRED:



- Use acrylic latex caulk that is paintable. Caulk at all horizontal and vertical seams, between the trim and walls, and all around the door trim.
- Use a high quality exterior acrylic latex paint. When painting your building, there are a few key areas that can be easily overlooked that must be painted:
 - Bottom edge of all siding and trim
 - Inside of doors and all 4 edges

Note:

Prime all un-primed exterior wood before painting.
(Follow directions provided by manufacturer.)

Building Size	Building Paint	Trim Paint	Caulk
12 x 8' (365,8 x 244,8 cm)	2 Gallons	2 Quarts	3 Tubes

ROOF FELT

- NOT INCLUDED -

- Install felt flush to all roof edges overlapping 3". Use minimal amount of roofing nails to hold in place.

OK to overlap at ridge.

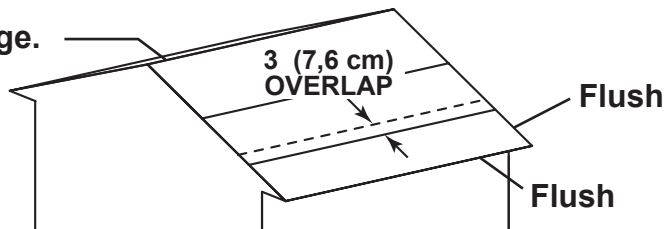

DRIP EDGE

- NOT INCLUDED -

- Install drip edge over roof felt on gable side and under roof felt on eave side (**Fig. A**).
- Do not use nails on side of drip edge that hangs over side of building.
- Only nail top of drip edge as shown.

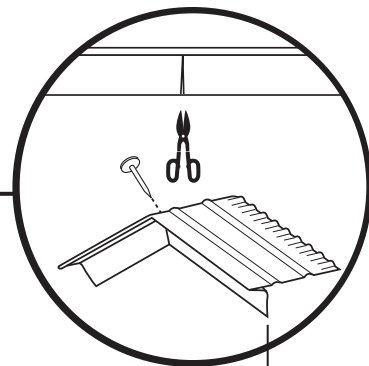
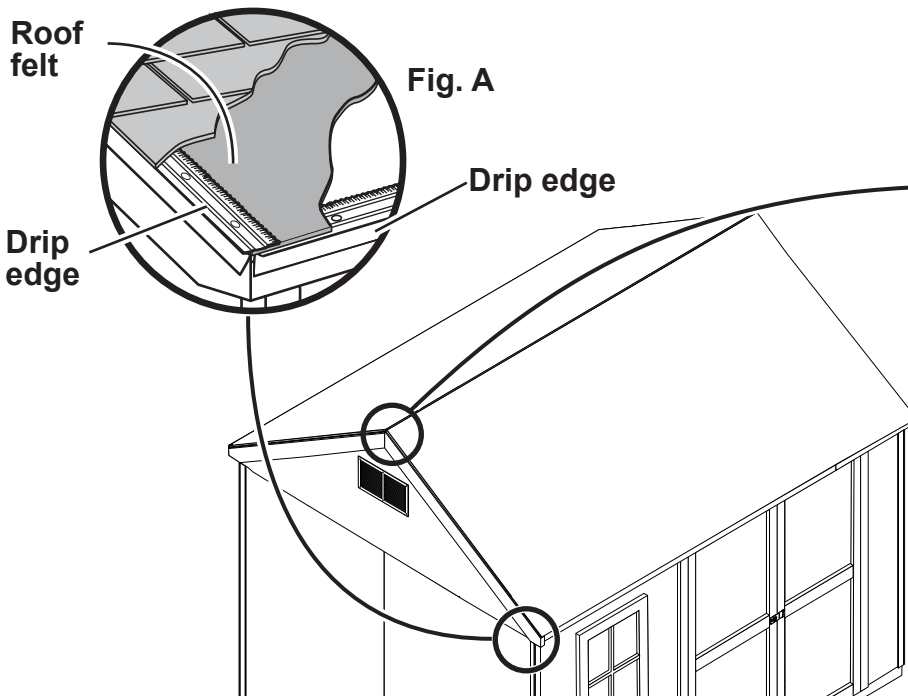

Edge flush to trim.

Snip bottom side of drip edge and bend over to other side of roof.

(Follow directions provided by manufacturer.)

Building Size	Drip Edge
12 x 8' (365,8 x 244,8 cm)	50' (15,2 m)

SHINGLES

- NOT INCLUDED -

• Follow directions provided by manufacturer and these instructions.



! Familiarize yourself with a 3-Tab Shingle.

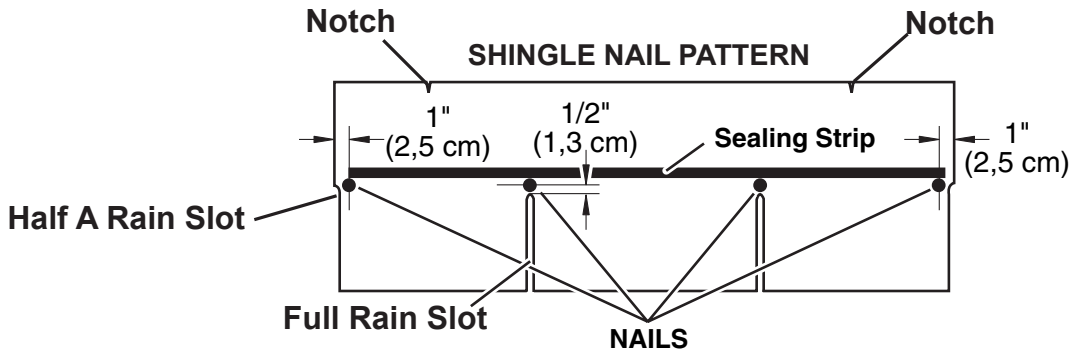

! NEVER DRIVE FASTENERS INTO OR ABOVE SEALING STRIPS.

✓ BEGIN

- 1** Install first starter row upside down and color up with a 1" overhang at back and bottom of roof panel. Use (4) nails per shingle. **Starter row must be straight and level all the way across with lower edge of roof deck.**
NOTE: If you have installed drip edge install shingles flush to drip edge.

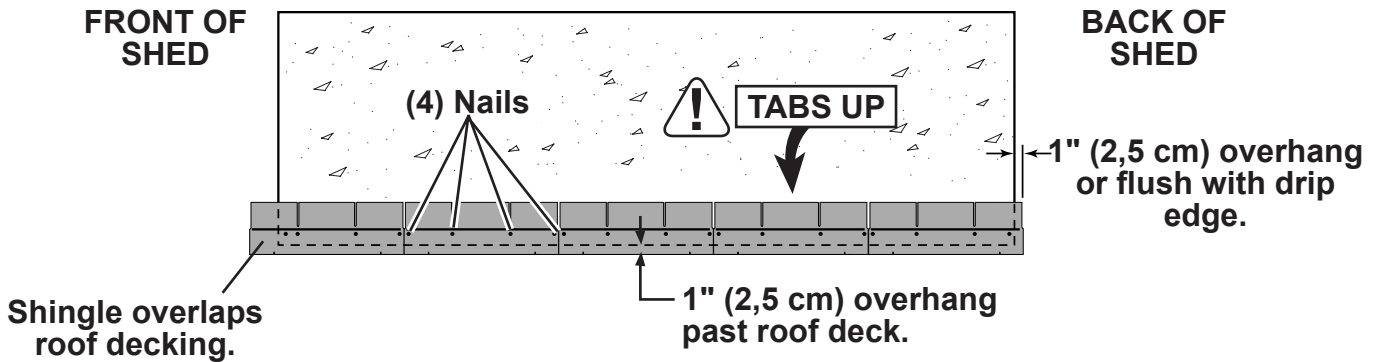

SHINGLES

continued...

- 2** Beginning at front of shed, install first row of shingles with notch at 1" past roof edge or flush with drip edge.

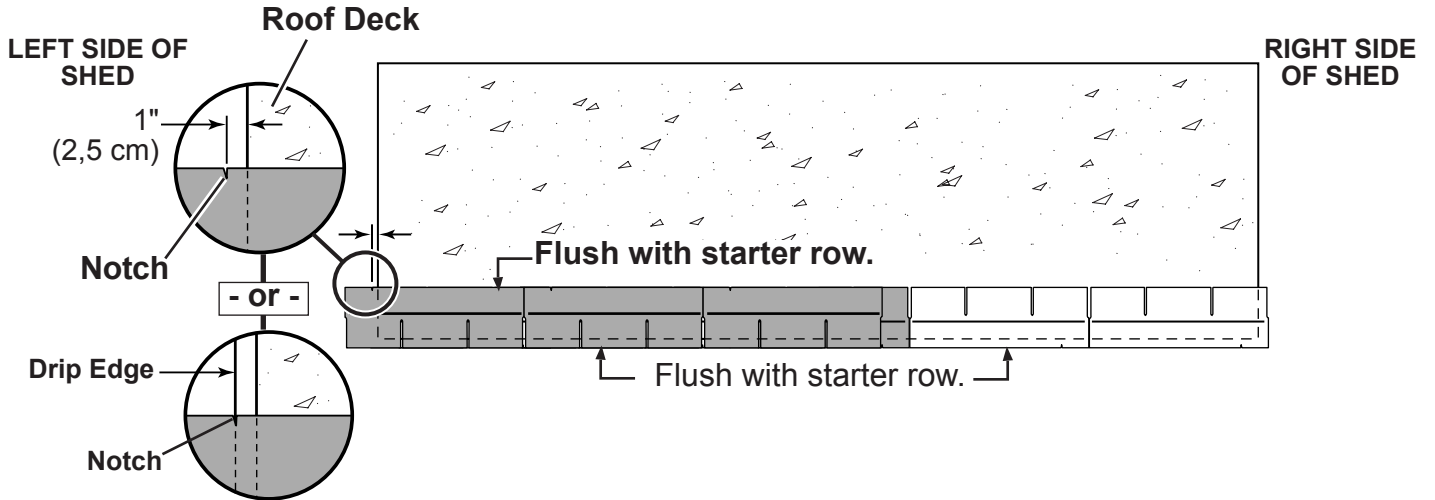

- 3** Install second row of shingles flush at top of first row's rain slots. Ensure 1" overhang or flush to drip edge at front, stagger each row.

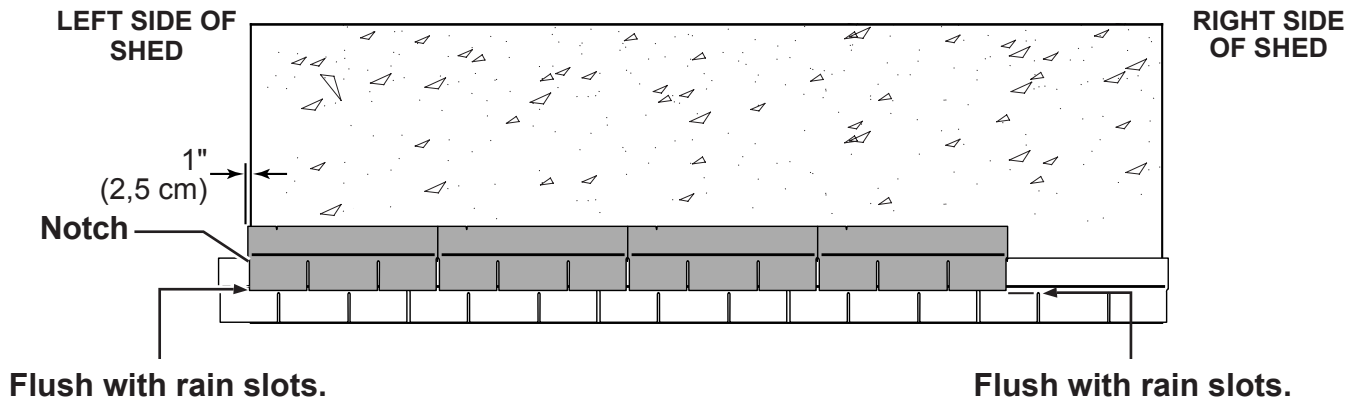

- 4** Continue installing rows of shingles by staggering at front.

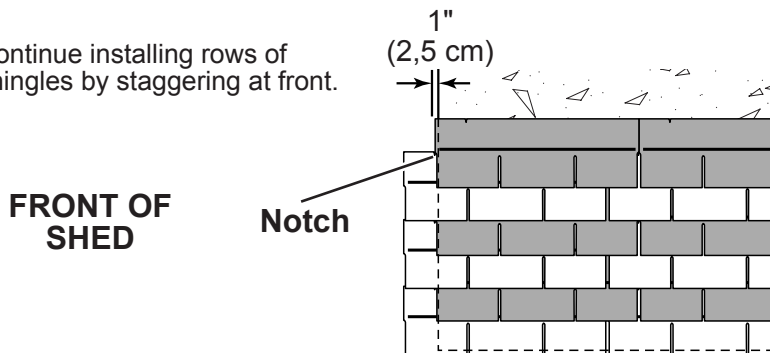

SHINGLES

continued...

- 5** Continue installing rows of shingles to the peak. At the peak make sure there is a maximum of 5" or less to the rain slot, as shown below. If shingles overlap at ridge cut to peak with a utility knife.

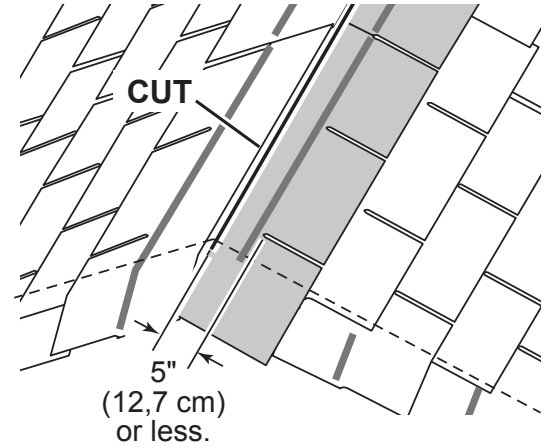
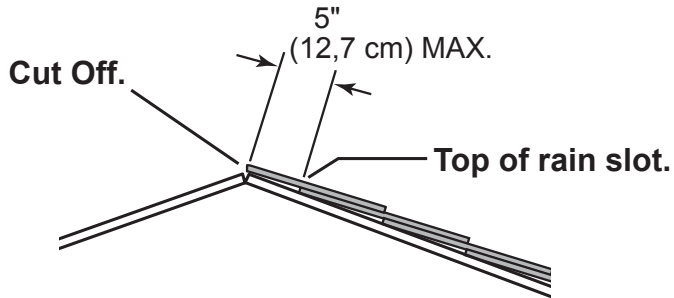

! • If more than 5" (12,7 cm) to rain slot you must install another row of shingles.

- 6** Repeat steps 1 - 5 to shingle the opposite side of your roof. Trim shingles at ridge.
- 7** Once both sides are shingled you need to trim ends. Strike a chalk line 1" from edge.
- 8** Using your shingle hooked blade carefully cut shingles along chalk line.

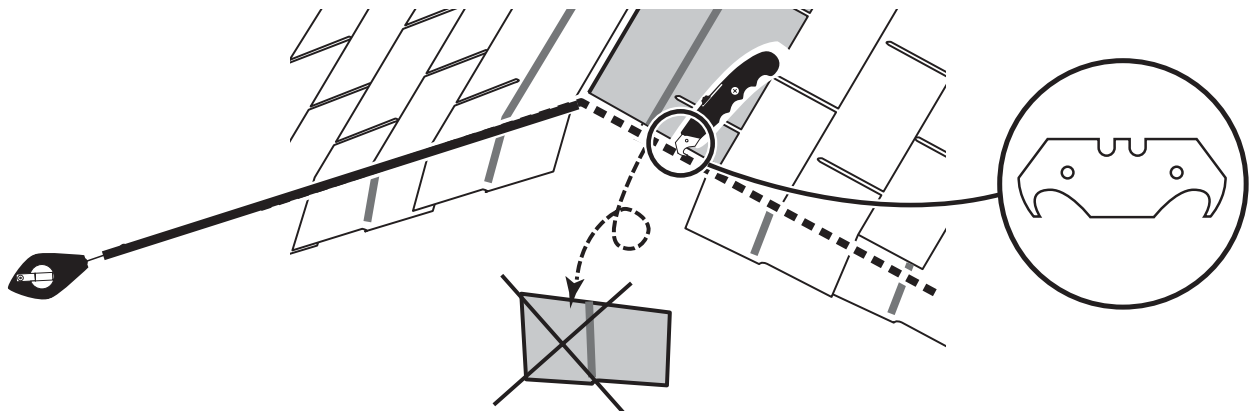

You have finished shingling your roof. Proceed to capping the ridge.

SHINGLES - RIDGE CAP



• You will finish off the top of the roof with a ridge cap made from shingles.

✓ **BEGIN**

1 Cut shingles into THREE pieces. **Hint:** Use cut-off pieces first.

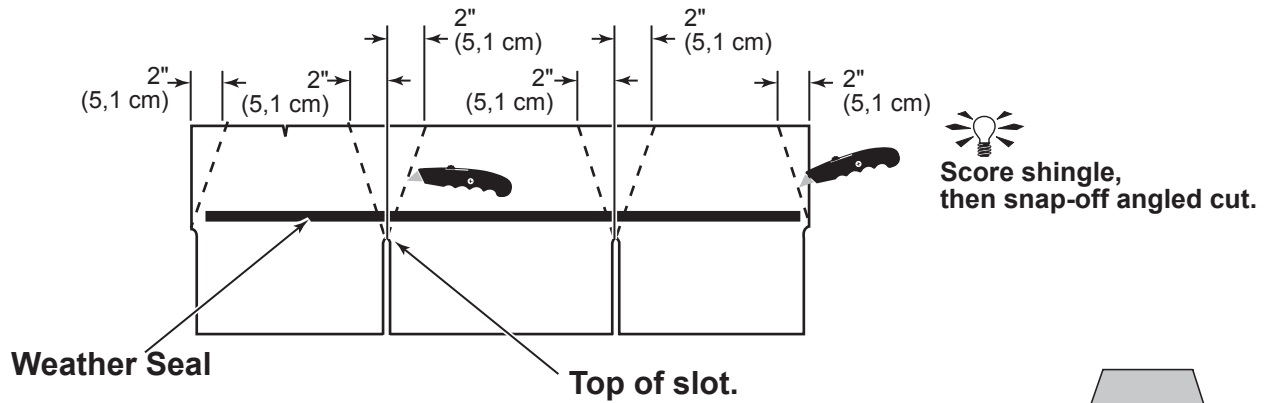

2 Install first ridge cap flush to shingles at front, as shown.

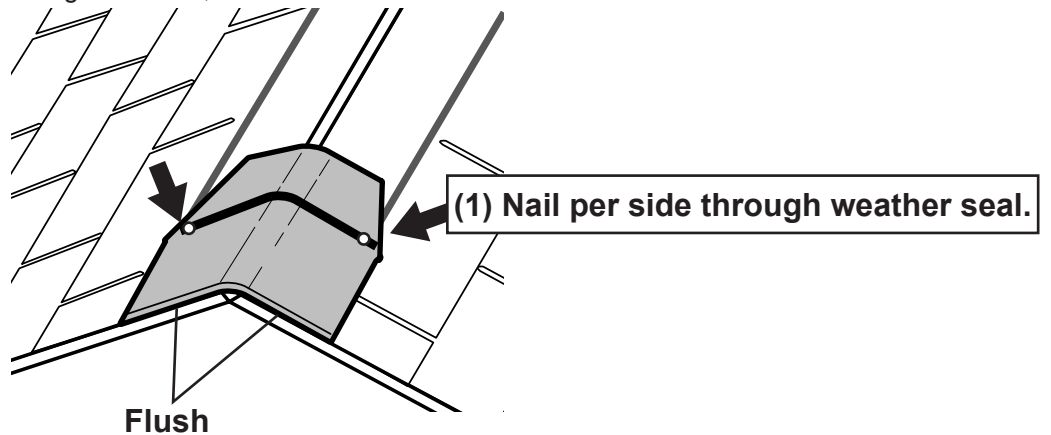

3 Install second ridge cap 5" back, as shown.

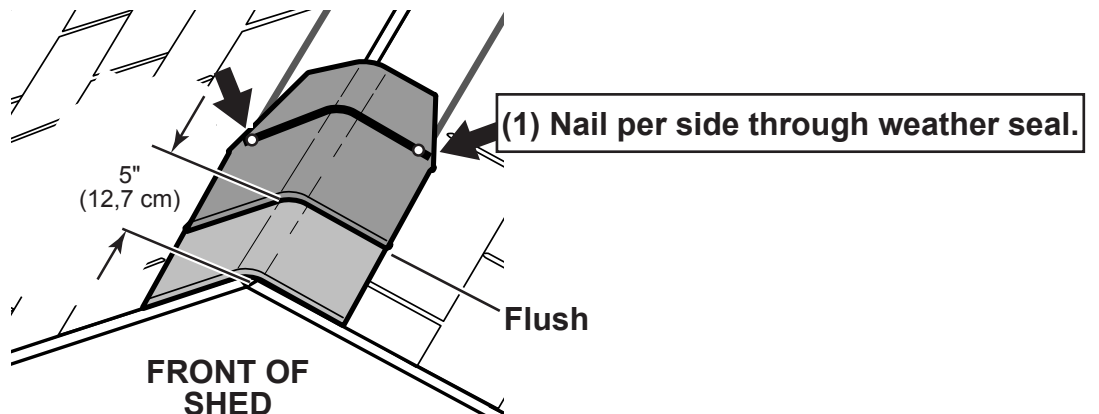

SHINGLES - RIDGE CAP

continued...

- 4 Continue installing ridge cap to back of roof.

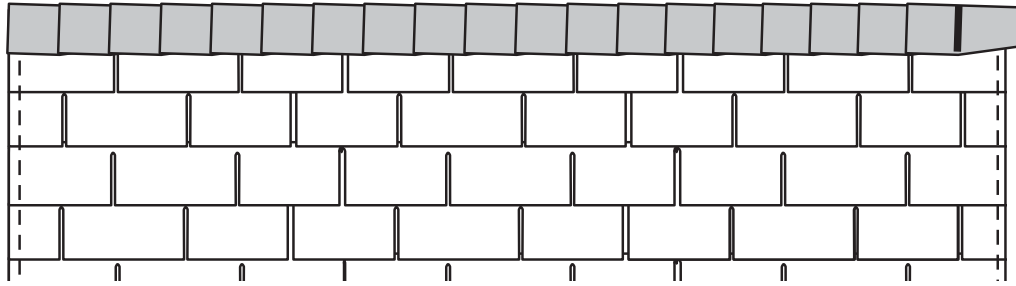

- 5 Make sure there is 4" (10,2 cm) between the shingle-color and edge of shingles.

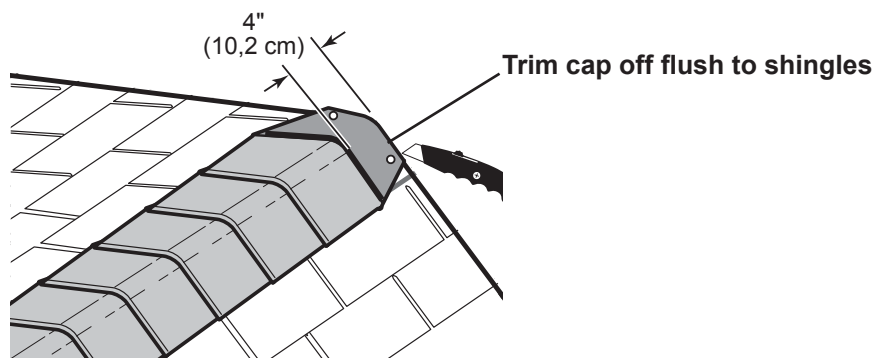

- 6 When you have 4" minimum of shingle color cut one piece to cap your roof.

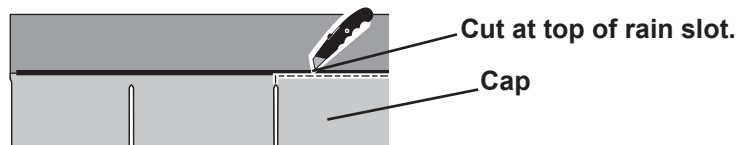

- 7 Install flush to shingles.

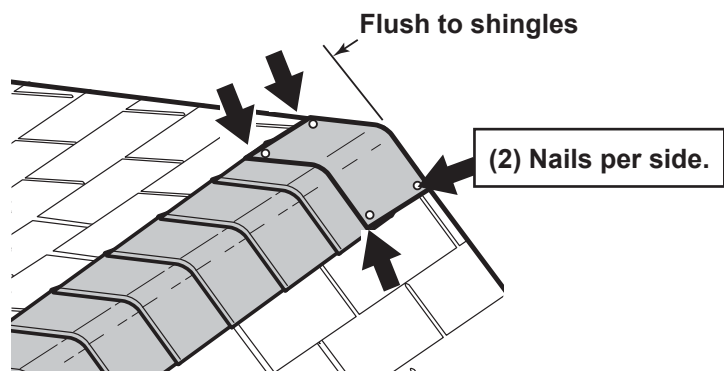

You have finished your ridge cap.

WARRANTY REGISTRATION

Please complete your warranty registration to properly validate your warranty.

Register your product online at: www.OnlineWarranty.net.

LIMITED CONDITIONAL WARRANTY*

Backyard Storage Solutions, LLC warrants the following:

1. Every product is warranted from defects in workmanship and manufacturing for 1 year.
2. All accessories, hardware and metal components are warranted for 2 years.
3. All Oriented Strand Board (OSB) is warranted for 2 years
4. Siding and Trim is warranted for 15 years.
5. Solar Shed windows are warranted for 1 year.
6. Cedar lumber is warranted for 15 years.
7. Preserved Pine is warranted for 10 years.

Backyard Storage Solutions, LLC will repair, replace or pay for the affected part. In no event shall Backyard Storage Solutions, LLC pay the cost of labor or installation or any other costs related thereto. All warranties are from date of purchase. If a cash refund is paid on an affected part, it will be prorated from the date of purchase.

CONDITIONS

The warranty is effective only when:

1. The unit has been erected in accordance with the assembly instructions.
2. The unit has been properly shingled and painted or stained and reasonably and regularly maintained thereafter.
3. The failure occurs when the unit is owned by the original purchaser.
4. Backyard Storage Solutions, LLC has received the warranty registration card within thirty (30) days of purchase and notification of the failure in writing within the warranty period specified above.
5. Backyard Storage Solutions, LLC has had reasonable opportunity during the sixty (60) days following receipt of notification to inspect and verify the failure prior to commencement of any repair work.

REQUIREMENTS

Storage Buildings

To validate your warranty, it is necessary to properly maintain your Backyard Storage Solutions, LLC unit; shingle the roof and paint or solid-colored stain the siding using quality, 100% acrylic latex exterior product with a minimum of two (2) coats within thirty (30) days of assembly; caulk above all doors and all horizontal and vertical trim boards; paint and seal all exposed edges, sides and faces of siding/trim and OSB siding to include all exterior walls and all sides and all edges of doors.

Gazebos & Pergolas

To validate your warranty, it is necessary to properly maintain your Backyard Storage Solutions, LLC unit. This includes treating all of the exposed cedar and pine surfaces on your gazebo or pergola structure with an exterior grade wood preservative, an exterior oil-based semi-transparent stain, an acrylic latex exterior paint or an acrylic latex solid color exterior stain within 30 days of assembly and as needed thereafter to maintain your warranty.

Keep vegetation trimmed away from building and make sure siding panels and trim do not come in contact with masonry or cement. The minimum ground clearance for siding must be one half inch ($\frac{1}{2}$ inch) from concrete slab or two and one half inches ($2\frac{1}{2}$ ") from the ground when building is erected or constructed on a treated wood floor kit. Water from sprinklers must be kept off unit. In no event will Backyard Storage Solutions, LLC be responsible for any indirect, incidental, consequential or special damages nor for failure(s) that are caused by events, acts or omissions beyond our control including, but not limited to, misuse or improper assembly, improper maintenance (which eventually leads to rot or decay) and acts of God. Backyard Storage Solutions, LLC will not be held responsible for any labor costs incurred to construct your unit.

This warranty gives you certain specific rights that vary from state to state.

CLAIM PROCEDURE

To make a claim under this warranty, you can either call 1-888-827-9056 or email: customerservice@backyardproducts.com.

Please have ready the information below when you call or include the information in your email:

1. The model and size of the product.
2. A list of the part(s) for which the claim is made.
3. Proof of purchase of the Backyard Storage Solutions, LLC item, as shown on the original invoice.
4. Run code: found on exterior product label or assembly instructions enclosed in the product package.

All other inquiries can be mailed to:

Backyard Storage Solutions, LLC
Attn: Customer Service
1000 Ternes
Monroe, MI 48162

***WARRANTY TERMS MAY VARY OUTSIDE THE U.S.A.**

IMPORTANT: This is your warranty certificate.

YDL LDR: 2/3/2016